

# 100

S E R I E S



## *Owner's Handbook*

*Instruktieboekje*

*Manuel du Conducteur*

*Betriebsanleitung*

*Manuale di Istruzioni*

*Manual del Conductor*

*Manual do Proprietário*





---

## 100 SERIES

---

### *Important Information*

---

**This information applies to Chelsea models ONLY and should be used in conjunction with the 'Technical Data' section of the Owner's Handbook, RCL 0162ENX.**

#### **Weights**

##### Three door models:

Chelsea (petrol)	840 kg
Chelsea (diesel)	890 kg

##### Five door models:

Chelsea (petrol)	855 kg
Chelsea (diesel)	905 kg

#### **Max towing weight (restart) on a 12%, 1 in 8 gradient with one passenger**

Chelsea petrol models	700 kg
Chelsea diesel models	460 kg



---

## 100 SERIES

---

### *Important Information*

---

This information is in addition to that shown under 'Lights & Indicators' in Owner's Handbook, RCL 0162ENX - 2nd Edition and applies to all Rover 100 cars equipped with Headlight Beam Height adjustment

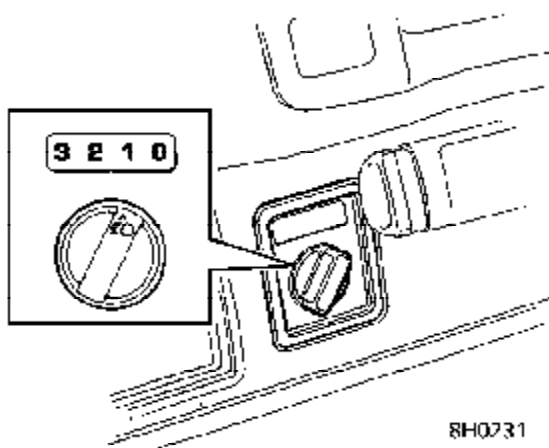

#### **Headlight beam height control**

The angle of the headlight beams is affected by the distribution of passenger and luggage weight within the car. It is important that the headlights are adjusted to ensure that the point at which they meet the road surface provides adequate illumination ahead of the car without dazzling other road users.

Using the following load conditions as a guide, adjust the height of the headlight beams by moving the control (arrowed in inset).

#### **Position 0:**

Driver, or driver and front seat passenger only (no luggage).

#### **Position 1:**

All seats occupied (no luggage).

#### **Position 2:**

All seats occupied and FULL luggage compartment.

#### **Position 3:**

Driver alone and FULL luggage compartment.

**Note:** These loading definitions assume that all loads will be within the limits of the maximum permissible axle and vehicle weights.

# Contents

---

## BEFORE YOU DRIVE

Controls	4	Windows	19
Locks	5	Heating & Ventilation	20
Alarm	7	Sunroof	22
Seats	10	Hood	23
Seat Belts	11	Interior Light & Clock	26
Airbag SRS	15	Cigar Lighter & Ashtrays	27
Mirrors	18	Load Carrying	28

---

## DRIVING CONTROLS

Identification Symbols	30	Automatic Gearbox	40
Driving Controls	31	Lights & Indicators	42
Instruments & Warning Lights	32	Switches	43
Starting & Driving	34	Wipers & Washers	44
Catalytic Converter	37	Brakes	45
Manual Gearbox	39	Fuel System	46

---

## MAINTENANCE

Maintaining Your Car	49	Braking System	56
Engine Compartment	50	Tyres	57
Bonnet Opening	52	Wipers & Washers	59
Engine	53	Battery	60
Engine & Heater Duct	54	Cleaning & Car Care	62
Cooling System	55		

---

## EMERGENCY INFORMATION

Emergency Starting	64	Fuses	70
Emergency Towing	66	Bulb Replacement	71
Wheel Changing	67	Parts & Accessories	74

---

## TECHNICAL DATA

Technical Data	75	Index	78
----------------	----	-------	----

---

# Introduction

---

Welcome to your new Rover. This handbook, together with the other publications in the literature pack, provides all the information you need to gain maximum pleasure from driving and owning your new car.

For your convenience, the handbook is divided into the following sections. Please take a little time to read them, and get to know your new Rover as soon as you possibly can.

**'Before You Drive'** - this section covers seat adjustment, seat belts and heating controls and deals with everything you need to know to settle comfortably into the car before you drive.

**'Driving Controls'** - here the functions and operation of the switches, instruments and driving controls are explained.

**'Maintenance'** - this part includes the Daily, Weekly and Monthly checks that you, the owner, should carry out. It also tells you how to do them.

**'Emergency Information'** - this section will help to solve a few of those unavoidable little problems that sometimes occur - like replacing bulbs and fuses, or changing a wheel.

**'Technical Data'** - here you will find the technical specification for your car.

## **WARNING!**

Always heed the advice given in a warning panel. This indicates either a procedure which must be followed precisely, or information that should be considered with great care to avoid the possibility of personal injury or serious damage to the vehicle.

**The specification of each Rover vehicle will vary according to territorial requirements and also from model to model within the vehicle range. Some of the information published in this handbook, therefore, may not apply to your car. If you are in any doubt, contact your dealer.**

Rover operate a policy of constant product improvement and therefore reserve the right to change specifications without notice at any time. Whilst every effort is made to ensure complete accuracy of the information in this handbook, no liabilities for inaccuracies or the consequences thereof, including loss or damage to property, or injury to persons, can be accepted by the manufacturer or the dealer who supplied the handbook, except in respect of personal injury caused by the negligence of the manufacturer or the dealer.



As part of Rover Cars environmental policy, this publication is printed on paper made from elemental chlorine-free pulp.

# *Literature pack*

---

*In addition to this handbook, your literature pack contains the following documents:*

- **Service Portfolio Book**
  - this book includes important information about Rover warranty and vehicle maintenance requirements, as well as containing a unique record of your own car's service history. Always hand this book to the service receptionist, and ensure your dealer completes the appropriate service record slip, whenever you take your car to a Rover dealer for service.
- **Security Information Card**
  - Your Rover dealer should have filled in all the relevant serial numbers concerning your car before delivery. These are important aids to security; remove the card from the literature pack and keep it in a safe place - NOT IN THE CAR.

*The literature pack is an important part of the car.  
Keep it in the glovebox where it is easy to find.*

# Controls

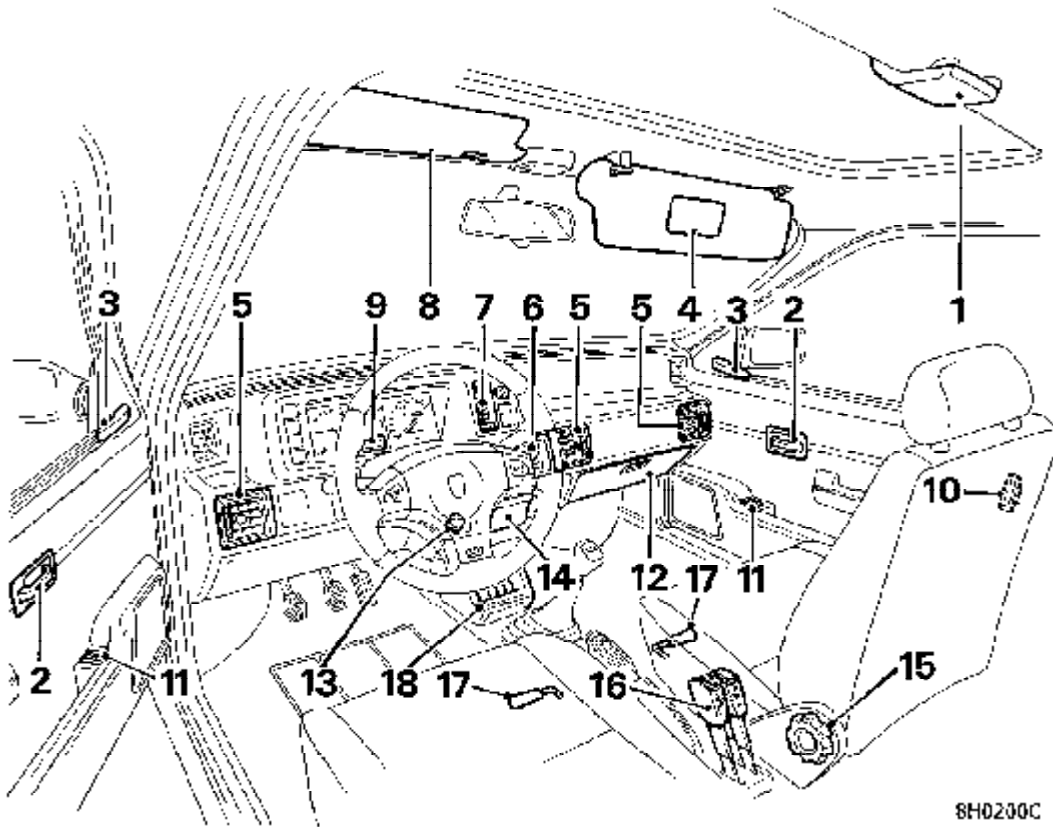

8H0200C

- |                                 |                              |
|---------------------------------|------------------------------|
| 1. Sunroof handle               | 10. Backrest release lever   |
| 2. Door release lever           | 11. Electric window switch   |
| 3. Door mirror adjustment lever | 12. Glovebox                 |
| 4. Vanity mirror                | 13. Cigar lighter            |
| 5. Face level vents             | 14. Ashtray                  |
| 6. Radio cassette player        | 15. Backrest angle adjuster  |
| 7. Heater controls              | 16. Seat belt locks          |
| 8. Sun visor                    | 17. Front seat release lever |
| 9. Clock                        | 18. Cassette holder          |

# Locks

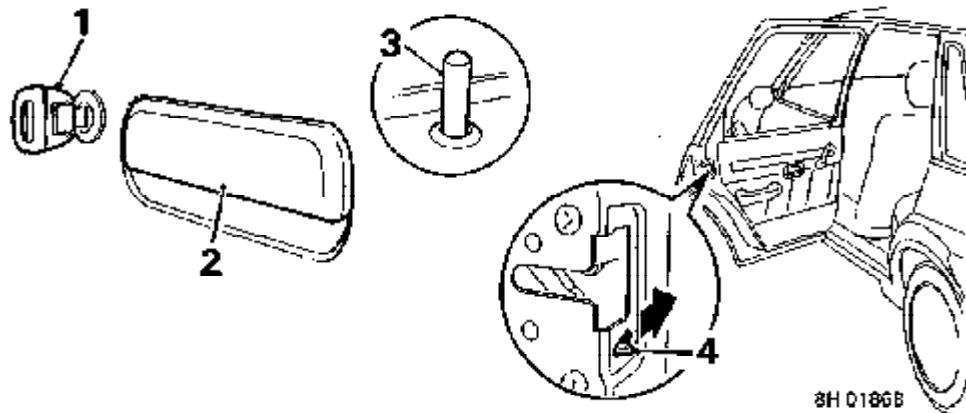

- 1. Door Lock Key**  
Turn towards front of car to lock.
- 2. Exterior Door Handle**  
Lift to open.
- 3. Interior Locking Button**  
Depress button to lock.
- 4. Child-proof Locking Lever (Rear doors only)**  
Move lever forward to activate.
- 5. Taildoor Lock**  
Turn key a half turn anti-clockwise to lock and a half turn clockwise to unlock. Depress locking button to open (see overleaf).

## LOCKS EXPLAINED

You have been supplied with two identical keys which operate all locks including the luggage compartment and the glovebox (Cabriolet models only).

The key number is stamped on a tag attached to your key ring. The tag is the only record of the key number and is essential should you ever need to obtain a replacement.

### IMPORTANT!

Ensure the key number is recorded on the Security Information card supplied with your literature pack - keep the card, key tag, spare key and handset in a safe place - not in the car.

## Manual Locking

The front doors may be unlocked or locked by using one of the keys, and each lock can be operated by raising or lowering the appropriate locking button from inside the car.

## Central Locking

The central locking system (fitted to most cars) electrically controls all door locks (including the taildoor) from a single point. Operation of the driver's door lock, from inside or outside, automatically activates all other locks at the same time.

Individual locks (other than the driver's door) may still be manually operated independently of the central locking system. However, it is important to remember that the system will not automatically re-engage individual locks.

**Visually check the locking buttons to be sure the doors are locked whenever you leave the car.**

**Note:** Each time the alarm is armed or disarmed (see 'Anti-theft alarm') the central locking system will also be activated.

## Child-proof Locking

With the child-proof locks engaged, the rear doors cannot be opened from inside the car, thereby avoiding the risk of a child accidentally opening a rear door while the car is moving.

# Locks

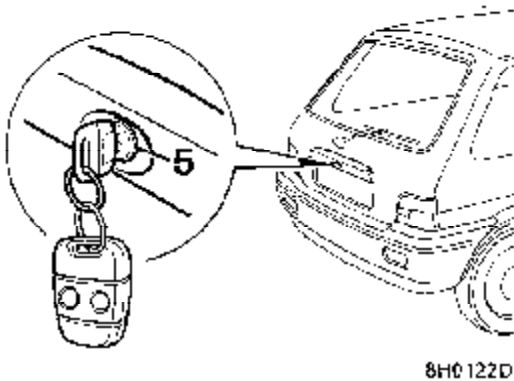

## Luggage Compartment

Take care to remove the key from the taildoor lock before shutting to prevent it breaking from the impact of the door closing.

### **WARNING!**

DO NOT drive with the taildoor open, as poisonous exhaust gases will enter the car.

## **ANTI-THEFT SECURITY PRECAUTIONS**

The theft of motor vehicles or their contents accounts for a very large proportion of all known crime. It pays to take precautions!

**Always adopt this simple "five point" drill whenever you leave your car - even for just a few minutes:**

- Fully close all windows (and sunroof).
- Remove any valuables (or hide them in the luggage compartment).
- Remove the starter key and handset.
- Engage the steering lock (by slightly turning the wheel until it locks).
- Lock all the doors (including the taildoor) and arm the alarm.

Even when you have done all these things, there is still much you can do to make your car a less inviting target for the thief.

### **BE SAFE NOT SORRY!**

- Try to park where your vehicle can be seen by householders or passers-by.
- At night always park in well lit areas and try to avoid dimly lit side streets.
- Never leave vehicle documents or spare keys in the car - these are a real bonus for the thief.
- If you have a garage, use it - and don't risk leaving the keys in the starter switch.
- Always unscrew and remove the radio aerial - an exposed aerial is an open invitation to vandals!

# Alarm

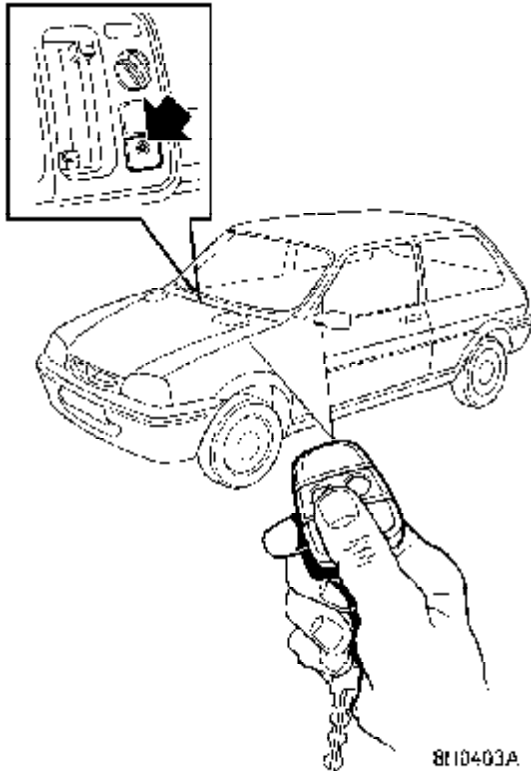

## **ANTI-THEFT ALARM (German Markets only)**

On cars equipped with central locking the doors and luggage compartment lock and unlock automatically when the alarm is armed and disarmed.

On cars without central locking, ensure that the doors, luggage compartment and bonnet are manually closed and locked before activating the alarm.

### ***Arming the Alarm:***

To arm the alarm, briefly press the 'PADLOCK' symbol handset button once:

- the alarm indicator light (arrowed in illustration) flashes rapidly for approximately ten seconds.
- on cars with central door locking, the doors and taildoor lock

After ten seconds the indicator light adjusts to a slower frequency and continues flashing once every second (as a visible theft deterrent) until the alarm is disarmed.

If a door, or the tailgate is opened, the alarm will be triggered; the horn will sound for approximately 30 seconds. In addition, the engine is immobilised and the horn will sound if the starter switch is operated.

### ***Disarming the Alarm:***

To disarm the alarm, press the smooth handset button:

- the alarm indicator light stops flashing.
- on cars equipped with central locking, the doors and tailgate unlock.

### **IMPORTANT!**

- The alarm can **ONLY** be armed and disarmed using the handset - if the doors are locked using the key the alarm will **NOT** be armed!
- With the alarm armed, any attempt to open a door or, on models equipped with central locking, to unlock a door using the key, will activate the alarm!

### **Engine immobilisation**

Engine immobilisation is a standard feature of the security system which occurs automatically whenever the alarm is set. As an additional safeguard, engine immobilisation also takes place 30 seconds after the starter switch is turned off and the driver's door is opened. This means that the engine will be immobilised whenever you leave the car - even if you have forgotten to lock the doors or arm the alarm!

### **IMPORTANT!**

When you return to your car, the engine can only be started after the smooth button on the handset has been pressed.

# Alarm

---

## **Partial Failure to Arm the Alarm:**

If the bonnet is left open, the alarm will not fully arm. This will be indicated by the alarm indicator light not illuminating for the first 5 seconds after pressing the handset button.

The car should not be left in this condition!

Close the bonnet and the alarm will automatically re-arm itself (the alarm indicator light flashes rapidly to confirm that the alarm is fully armed).

## **Cabriolet Models**

In addition, the alarm system on some Cabriolet models features interior space protection, whereby a sensor inside the passenger compartment monitors any movement inside the car, and activates the alarm if a disturbance is detected.

If interior space protection is fitted to your car, it will be activated automatically whenever the alarm system is armed.

### **IMPORTANT!**

To prevent false alarms on cars fitted with interior space protection, DO NOT arm the alarm if passengers or animals are to be left inside - any movement may activate the alarm!

### **WARNING!**

In the interests of security, ALWAYS arm the alarm whenever you leave the car - even for a short while - and NEVER leave the car with windows, hood or sun roof open even if the alarm is armed!

## **Using the Handset**

Each time one of the handset buttons is pressed the radio signal code changes. If the handset battery has been replaced or the car battery disconnected, the sequence of signals between the handset and receiver will be lost. It is then necessary to re-synchronise the handset as follows:

Unlock the car with the key and, holding the handset close to the car, press the dimpled (lock) button four or more times in quick succession.

When locking, it is wise to observe the door locking buttons; these should all 'drop' to the locked position.

As the handset battery nears the end of its life you will notice that the operating range of the handset will decrease, the handset buttons will only work every other press and the alarm light will continue to flash for approximately 10 seconds when the vehicle is unlocked (see replacing the batteries).

### **WARNING!**

The handset contains delicate electronic circuits and must be protected from impact and water damage, high temperatures and humidity, direct sunlight and effects of solvents, waxes and abrasive cleaners.

**Note:** Additional or replacement handsets are available from a Rover dealer.

# Alarm

---

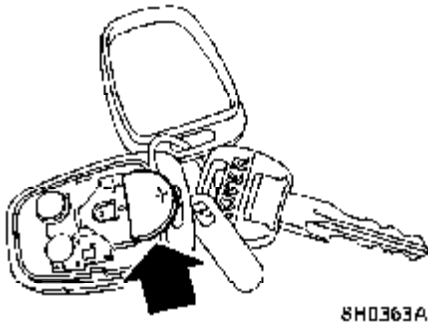

## Replacing the Battery

Battery life will vary according to use. Always fit a 'Unipart YWK 10003' replacement battery (available from your Rover dealer), and adopt the following replacement procedure:

1. Carefully prise the handset apart (start from the keyring end), using a coin or small screwdriver.
2. Slide the battery out of its clip, taking care to avoid touching the circuit board and the contact surfaces of the clip.
3. Press and hold one of the buttons on the handset for at least 5 seconds (this will drain any residual power from the handset).
4. Fit new battery and ensure that the polarity is correctly maintained (fit battery with the positive ('+') side facing up). Finger marks will adversely affect battery life - if possible, avoid touching the flat surfaces of the battery and wipe clean before fitting.
5. Reassemble the two halves of the handset.
6. Unlock the car with the key and synchronise the handset by holding the handset close to the car and pressing the dimpled (lock) button four times or more in quick succession.

# Seats

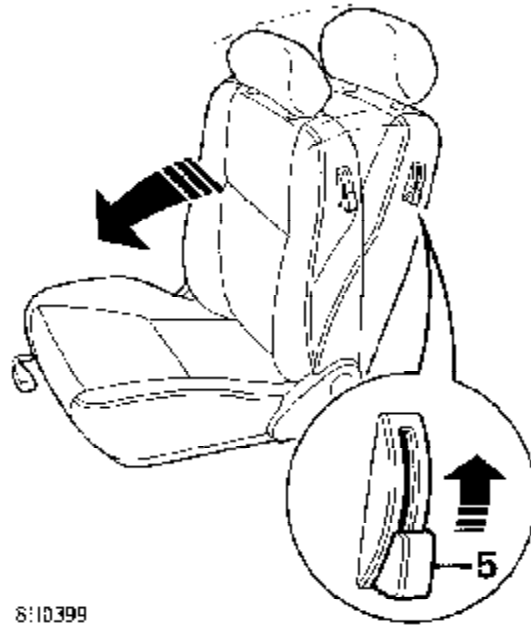
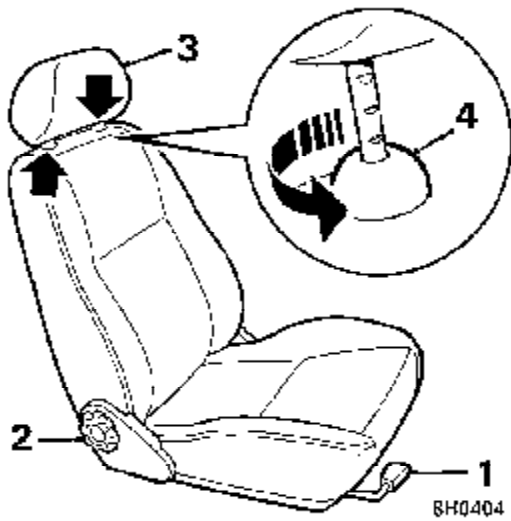

## 1. Forward/Backward Adjustment

Lift the lever to slide the seat forward or back. Lower the lever and check the seat is locked in position before driving.

## 2. Backrest Angle Adjustment

Ease your body weight from the backrest and rotate the handwheel to adjust the backrest to the required angle.

## 3. Head Restraint Adjustment

Move the padded cushion up or down to raise or lower the head restraint.

## 4. Head Restraint Removal

To remove a head restraint: Turn both of the bevelled mountings a quarter turn anti-clockwise. Turn the mountings clockwise after the head restraint has been replaced.

## 5. Backrest Release Lever (3 door models only)

Lift the lever to fold the backrest forward and gain access to rear seats. Ensure the backrest is securely locked in the upright position before driving.

### **WARNING!**

- DO NOT adjust the seats while the car is in motion.
- DO NOT allow front seat occupants to travel with the seat backs reclined steeply rearwards. Optimum benefit is obtained from the seat belt with the seat back angle set to 25 degrees from the upright (vertical) position.

### **HEAD RESTRAINTS**

Head restraints are fitted for safety and should be adjusted level with the back of the head and NOT the neck. Properly adjusted head restraints can considerably reduce the risk of neck or head injuries and, for this reason, you should never carry passengers in seats where the head restraints have been removed.

If a head restraint is removed in order to fully recline a seat, be sure it is refitted the right way round (angled forward towards the head).

### **REAR SEATS**

The rear seats can be folded forwards in order to increase the luggage area (see 'Load Carrying').

# Seat Belts

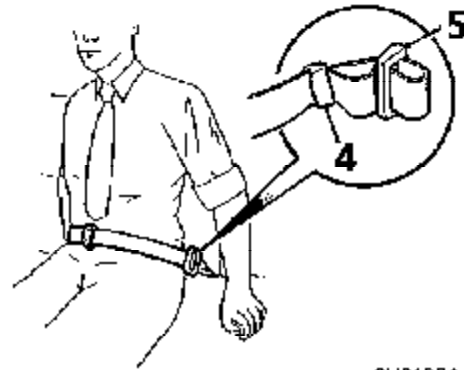
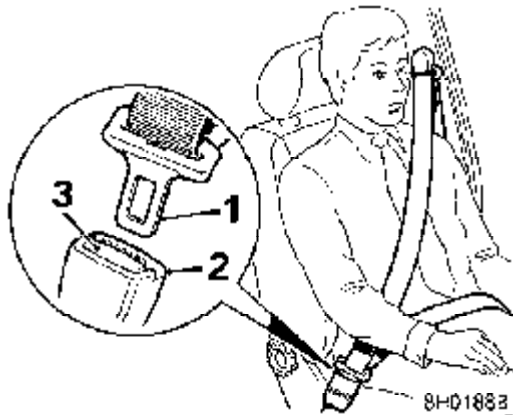

1. Tongue Plate
2. Lock
3. Lock Release Button

1. Centre Rear Belt Adjuster \*
2. Centre Rear Belt Buckle \*  
Feed webbing through buckle to adjust belt length.

To minimise injury in the event of an accident, it is important that seat belts are worn correctly. Read the instructions below and the advice contained under the heading 'Seat Belt Safety' on the pages that follow.

## WEARING SEAT BELTS

To fasten, pull the tongue plate over your shoulder and push it into the lock nearest you; a click indicates that the belt is locked in position. To release, press the RED release button.

To reduce the risk of injury, seat belts should be worn with the webbing crossing the midpoint of the shoulder and NOT resting on the neck.

- DO reposition the front seat belt anchorage points to suit the height of the usual occupants.

Rear seat passengers should move either nearer to or further away from the centre of the car to enable the seat belt webbing to cross the shoulder without pressing on the neck.

### Centre Rear Belt

The central rear seating position in saloon cars is fitted with a lap belt only. This must be manually adjusted by sliding the adjuster along the belt and feeding the webbing through the buckle until the belt is comfortably tight.

\* Not Cabriolet model

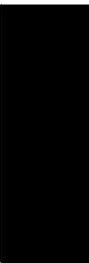

# Seat Belts

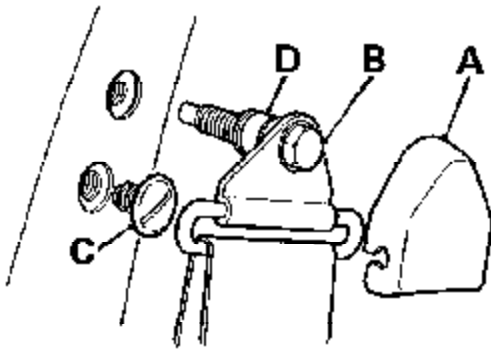

8H 0127

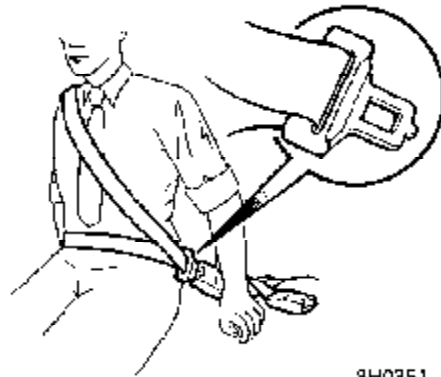

8H0351

## Repositioning the Front Anchorage Point \*

Each front seat belt has two anchorage points at different heights. If necessary, reposition the anchorage so that the belt crosses the midpoint of the shoulder without touching the neck, as follows:

Unclip the plastic cap (A) and unscrew the mounting bolt (B). Unscrew the blanking plug (C) from the alternative anchorage point and attach the seat belt mounting bolt in its place. Ensure the washers (D) are correctly positioned as shown, and then **FIRMLY TIGHTEN** the mounting bolt to 32 Nm using a 17 mm spanner.

\* Not Cabriolet model

## Rear Seat Belts (Cabriolet model)

Rear seat belt locks must cross over when in use. The lock furthest from the user must be used.

**Note:** The locks are inhibited to prevent incorrect attachment.

# Seat Belts

## Caring for Seat Belts

Regularly inspect the belt webbing for signs of abrasion or wear, paying particular attention to the fixing points. Always replace a seat belt that has withstood the strain of an impact or shows signs of fraying.

### Three Tests for Checking Seat Belts

1. With the seat belt fitted, give the webbing near the lock a quick upward pull. It must remain securely locked.
2. With the seat belt unfastened, unreel the webbing to the limit of its travel. Check that unreeling is free from snatches and snags.
3. With the webbing half unreeled, give the tongue plate a quick forward pull. The safety mechanism must lock automatically and prevent any further unreeling.

If a seat belt should fail any of these tests, contact your dealer immediately.

## CHILD SEATS

In any car accident, children are as vulnerable as adults. It makes sense to ensure they are properly restrained.

A range of seats approved for use in Rover cars is available from your Dealer, who will advise which type of seat is most suitable for your child.

Child safety seat straps can be attached to the rear seat anchorage points (arrowed in illustration) using the fixings supplied with the child safety seat. To gain access to the anchorage points, fold the rear seat and backrest forward and fold back the luggage floor covering.

Be sure to abide by the installation instructions provided with child seats.

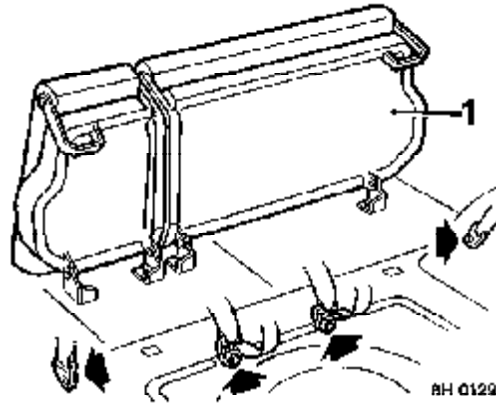

# Seat Belts

## SEAT BELT SAFETY

The seat belts fitted to your car are intended for use by adult sized occupants only. Seat belts are life saving equipment. In a collision unrestrained passengers can be thrown around inside, or possibly thrown out of the car, resulting in injury to themselves and to other occupants as well.

### ENSURE that ALL passengers are securely strapped in at all times.

- **ALWAYS** adjust seat belts to eliminate any slack in the webbing. **DO NOT** slacken the webbing by pulling the belt away from the body - to be fully effective, the seat belt must remain in full contact with the body at all times.
- **ALWAYS** fit the lap strap as low on the hips as possible (never across the abdomen), and ensure that the diagonal belt passes across the chest, without slipping off the shoulder, or pressing against the neck.
- **DO NOT** allow a baby or infant to be carried on the lap. The force of a crash can increase effective body weight by as much as 30 times, making it impossible to hold on to the child.
- **NEVER** fit more than one person into a belt, or fit a seat belt that is twisted or obstructed in any way that could impede its smooth operation.
- **DO NOT** wear seat belts over hard or fragile items in clothing, such as pens, keys, spectacles etc.
- **DO NOT** allow front seat occupants to travel with the seat backs reclined steeply rearwards. Optimum benefit is obtained from the seat belt if the seat back angle is set to 25 degrees from the upright (vertical) position.
- **ALWAYS** replace a seat belt assembly that has withstood the strain of a severe vehicle impact, or one where the webbing shows signs of fraying.
- **DO NOT** allow foreign matter (particularly sugary food and drink particles) to enter the seat belt buckles - such substances can render the buckles inoperative.
- **DO** use the seat belts to secure large items of luggage that are to be carried on the seats - in the event of an accident, insecure items become flying missiles capable of causing serious injury.
- Pregnant women should ask a doctor for advice about the safest way to wear seat belts.

# Airbag SRS



The airbag supplementary restraint system (SRS) (if fitted) provides additional protection for the driver in the event of a severe frontal impact on the car.

**Always remember; the airbag is a supplemental restraint system that provides ADDITIONAL protection in a frontal impact only and in no way replaces the need to wear a seat belt.**

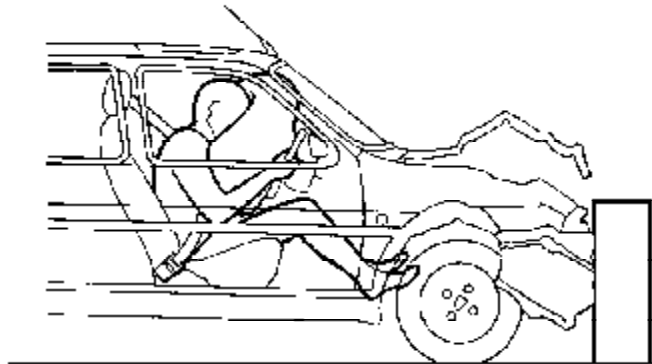
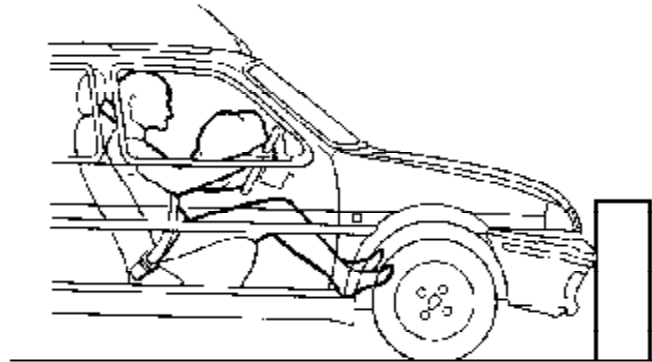
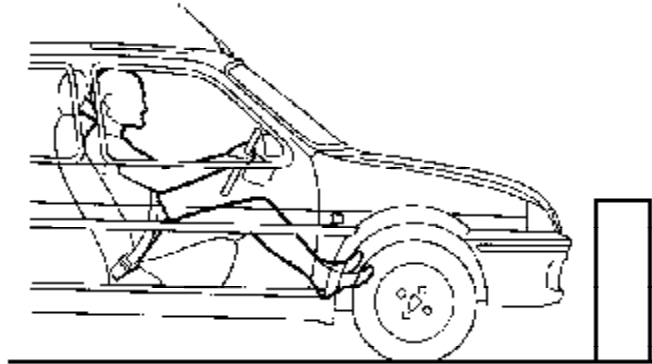

8H04C6

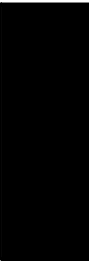

# Airbag SRS

The SRS logo consists of the letters 'SRS' in a bold, sans-serif font, enclosed within a rectangular border.

## How the Airbag SRS Works

In the event of an accident involving a frontal impact, a sensor monitors the force of the impact to determine whether the airbag should be inflated.

The airbag is contained within the steering wheel centre pad, and inflation is instantaneous and accompanied by a loud noise. Also evident are traces of smoke and powder, neither of which are indicative of a malfunction of the airbag.

After inflation, the airbag immediately deflates, thereby ensuring that the driver's visibility is not impaired.

## Safety Information

Even with an airbag SRS, the driver must ALWAYS wear a seat belt, because:

- The airbag will only inflate in a severe frontal collision. It will not inflate in the event of side or rear impacts, roll over accidents, or minor frontal impacts.
- The airbag inflates and deflates very quickly and will not protect the driver against the effects of secondary impacts that can sometimes occur during multiple collisions.

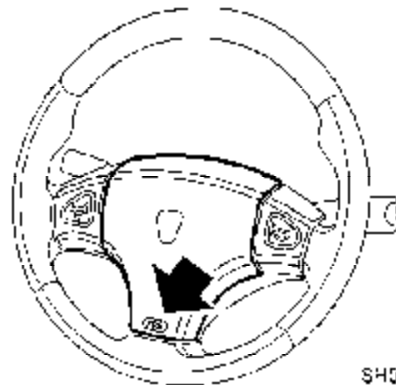

SH0397

## Airbag SRS Warning Light

The warning light (arrowed) located in the steering wheel pad will alert you to any malfunction of the airbag SRS. The system should be checked by your Rover dealer if:

- The warning light fails to illuminate when the starter switch is turned on (position 'II').
- The light fails to extinguish within approximately three seconds after the starter switch is turned to position 'II'.
- The light illuminates while the engine is running.

## WARNING!

- After inflation, some airbag components are hot - DO NOT touch until they have cooled.
- An airbag inflates with considerable force and can cause facial abrasions and other injuries. The injurious effects of airbag inflation can be minimised by ensuring that the driver's seat is properly positioned and the seat belt worn correctly.
- NEVER attach accessory items to the steering wheel centre pad; these could interfere with the inflation of the airbag, or if the airbag inflates, be propelled inside the car causing injury to the occupants.

# Airbag SRS



## Service Information

After a period of 10 years from the date of registration (or date of installation of a replacement airbag SRS), some components will need to be replaced (note the 'airbag module replacement date' shown on page 2 of the Service Portfolio Book). To ensure absolute safety, any work carried out on an airbag SRS must be undertaken by a Rover dealer, who should stamp and sign the appropriate page of the Service Portfolio book once the work is complete.

In addition, ALWAYS contact your Rover dealer if:

- the airbag module inflates.
- the front of the car is damaged (even if the airbag has not inflated).
- any part of the airbag module cover (steering wheel centre pad) shows signs of cracking or damage.

## WARNING!

DO NOT attempt to service, repair, replace or modify any part of the airbag SRS; tampering with any airbag component could cause inadvertent activation of the system, resulting in personal injury.

## IMPORTANT!

The airbag SRS components are sensitive to electrical or physical interference either of which could easily damage the system, causing inadvertent operation or a malfunction of the airbag.

ALWAYS seek the assistance of a Rover dealer to carry out any of the following:

- The removal or repair of any component or wiring in the vicinity of the SRS components (yellow wiring harness), including; the steering wheel, steering column, instrument and fascia panels.
- Installing electronic equipment such as; a mobile telephone, two-way radio or in-car entertainment system.
- Attachment of accessories to, or modification of, the front of the car.

In addition:

If you sell your car, be sure to inform the new owner that the car has an airbag SRS system, and make the new owner aware of the airbag module replacement date shown in the Service Portfolio book.

If the car is to be scrapped; an uninflated airbag is potentially very dangerous and must be safely deployed in a controlled environment before the car is scrapped.



# Mirrors

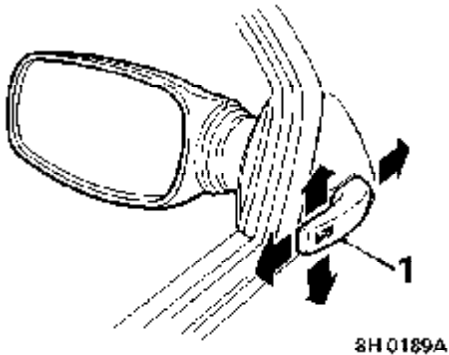

## 1. Adjustment Lever

Push the lever up, down, forward or back to move the mirror glass into the required position.

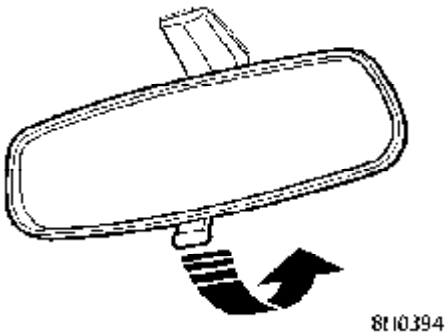

## INTERIOR MIRROR

The interior mirror is equipped with an anti-dazzle dip facility.

At night, by moving the lever at the bottom of the mirror forward, you can eliminate dazzle from following vehicles. To return the mirror to its normal position, steady the front of the mirror glass with your thumb while pulling the lever back to its original position.

### WARNING!

In some circumstances the view reflected in a 'dipped mirror' can confuse the driver as to the precise position of following or over-taking vehicles. Remember to take additional care!

## Vanity Mirror

To avoid possible scorching of the seats, caused by the sun being reflected in the vanity mirror, always return the passenger sun visor to its stowed position when not in use.

## DOOR MIRRORS

Both door mirrors are spring loaded and will fold forward or backward on impact. The mirrors can also be folded back into a park position to aid entry through narrow openings: holding the interior adjustment lever steady, pull the mirror body back towards the side window until it 'clicks' into the park position.

Push the mirror forward to reset in the driving position, then check the mirror setting.

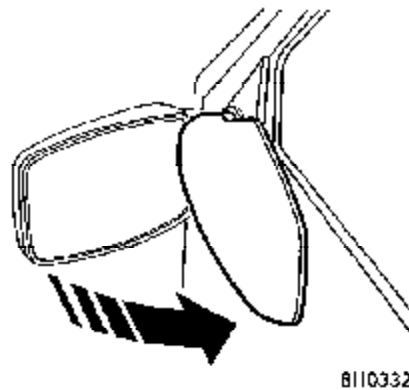

# Windows

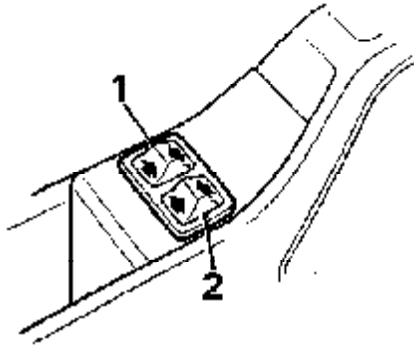

8H 019C

## **ELECTRIC FRONT WINDOW SWITCHES**

Push forward to raise and rearward to lower.

### **1. Driver's Window Switch**

### **2. Passenger Window Switch**

## **OPERATING ELECTRIC WINDOWS**

On some models both front windows can be operated electrically from switches mounted on the driver's door when the starter switch is at position 'I'. The switch on the passenger door operates the passenger window only.

Do not attempt to raise or lower a window that is jammed by ice. If a window is obstructed during operation, a cut-out will render it inoperative. Clear the obstruction and wait 15 seconds before re-operating the window.

## **WARNING!**

Accidental closing of an electrically operated window on fingers, hands or on any other vulnerable parts of the body, can result in serious injury!

Always heed the following precautions:

- ENSURE children are kept clear whilst raising or lowering windows.
- DO NOT leave children alone in the car.
- ENSURE that all adult passengers are familiar with the controls and the potential dangers of electrically operated windows.



# Heating & Ventilation

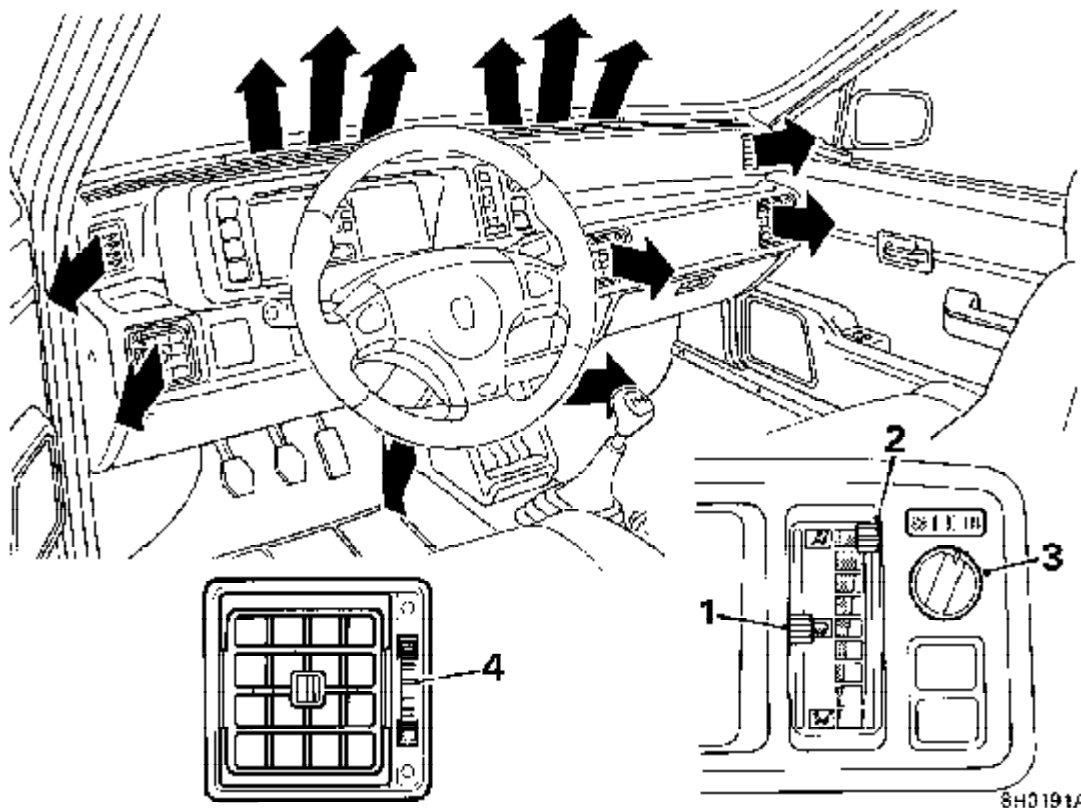

8H0191A

## 1. Air Distribution Control



Maximum face level ventilation only (no air from screen or foot vents).



Maximum air flow from windscreen and side window vents (some air from face level vents).



Maximum air flow from foot vents (some air from windscreen and face level vents).

## 2. Air Temperature Control

BLUE: Unheated air RED: Heated air

## 3. Blower Switch

'I' - normal heating or ventilation.

'II' - maximum heating or demisting.

'III' - maximum ventilation or defrosting.

## 4. Face Level Vents

To regulate the air flow, rotate the thumbwheel down to open and up to close. Use the knob in the centre of each vent to adjust the direction of air flow - up, down, left or right.

### WARNING!

Do not use the blower when the face level vents are closed and the air distribution control is at position 

# Heating & Ventilation

## USING YOUR HEATER

Fresh air enters the heater through the air intake grills in front of the windscreen. These must always be kept clear of obstructions, including snow and ice. Stale air is automatically drawn out through vents in the taildoor.

The following examples show three basic heating and ventilation settings. Further adjustment of the air distribution, temperature and blower controls will give a wider range of options, enabling you to always obtain the best results from the heater unit.

### Points to Remember:

- With the blower off, the volume of air entering the car is dependent upon driving speed alone.
- Full heating is not available until the engine has reached its normal operating temperature.
- Fresh air flow from the face level vents is increased by opening the rear window vents or sunroof.

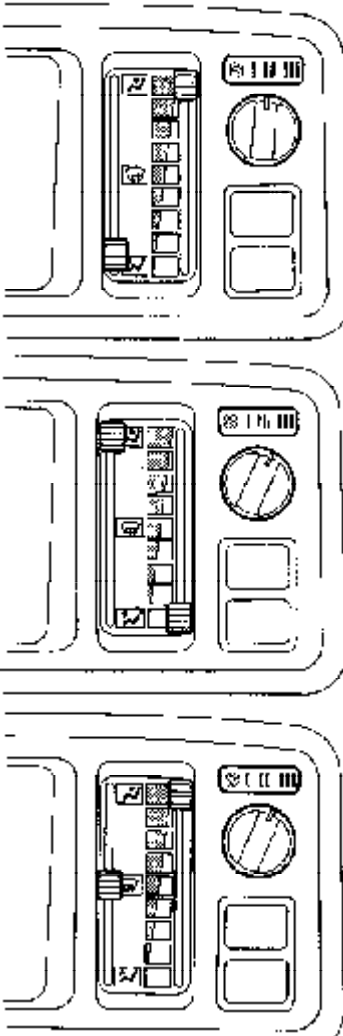

The image contains three diagrams of a car's climate control panel, each showing a different setting. The top diagram is for 'Heating', the middle for 'Maximum Ventilation', and the bottom for 'Demist or Defrost Windscreen'. Each diagram shows the air distribution control knob, the temperature gauge, and the blower speed control. The bottom diagram is labeled '8H0192A'.

**Heating**  
Set the controls as shown as soon as the temperature gauge indicates that the engine is warming up. Keep the face level vents closed and adjust the blower speed to suit your requirements.

**Maximum Ventilation**  
Set the controls as shown. Open all the face level vents and adjust the direction of air flow. Adjust the blower speed as required.  
**Note:** If face level ventilation only is required, the air distribution control **MUST** be set as shown.

**Demist or Defrost Windscreen**  
Set the controls as shown to obtain maximum heated air flow from windscreen and side window vents. Keep the face level vents closed but, if necessary, direct air from the outer face level vents onto the side windows.

# Sunroof

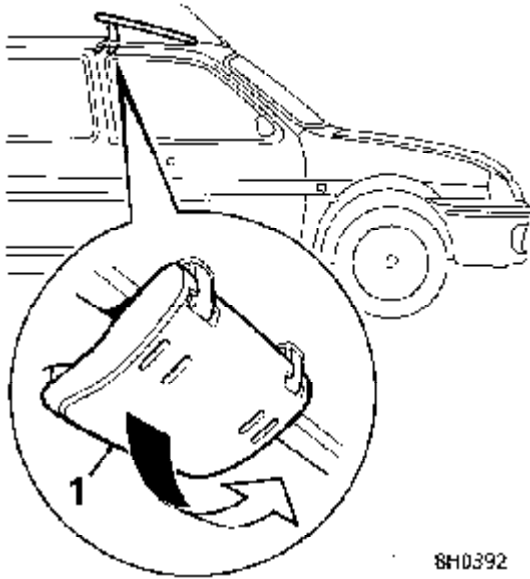

8H0392

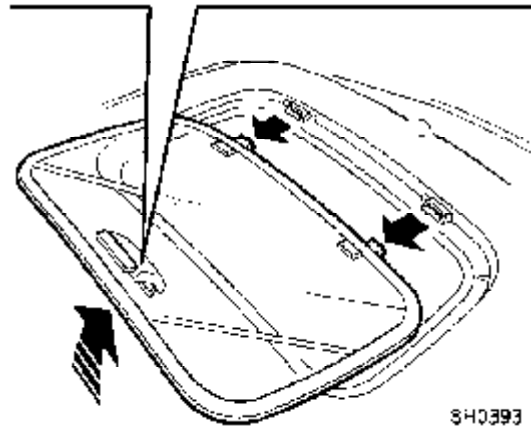
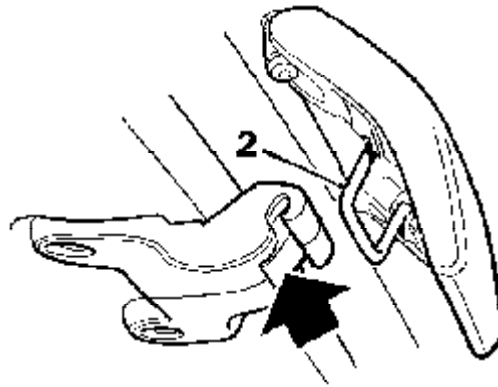

8H0393

## 1. Sunroof Operating Handle

Pull the handle forward (to unlock), then push the handle up (to tilt the sunroof open). Pull the handle to the rear to lock the sunroof in the open position.

## 2. Sunroof Linkage

Press the RED button to disconnect the operating handle (see 'removing the sunroof').

### USING THE SUNROOF

Points to note:

- Do not allow passengers to extend any part of their bodies through the sunroof aperture while the car is moving - they could be injured by flying debris, branches of trees or other obstructions.
- Make sure you close the roof whenever the car is left unattended.
- NEVER attempt to remove the sunroof while the car is in motion.

### REMOVING THE SUNROOF

Tilt the roof and disconnect the operating handle by pressing the RED release button. From outside the car, lift the sunroof rearwards until the locating lugs are clear of the car.

After removal, use a rug or blanket to protect the sunroof from scratches or accidental damage and store it in the luggage compartment.

When replacing, ensure both sunroof locating lugs (arrowed in illustration) are fully engaged with the main roof panel, before connecting the operating handle and closing the roof.

# Hood

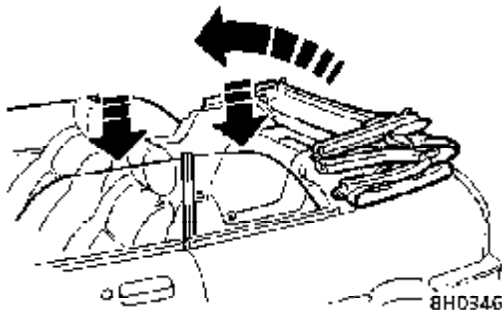
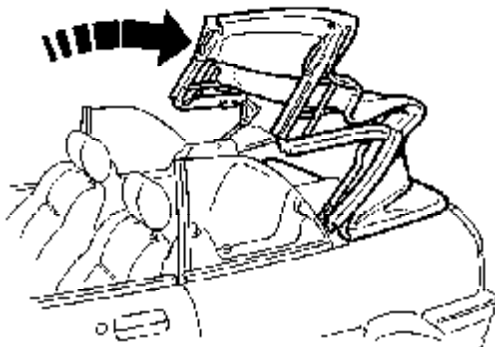
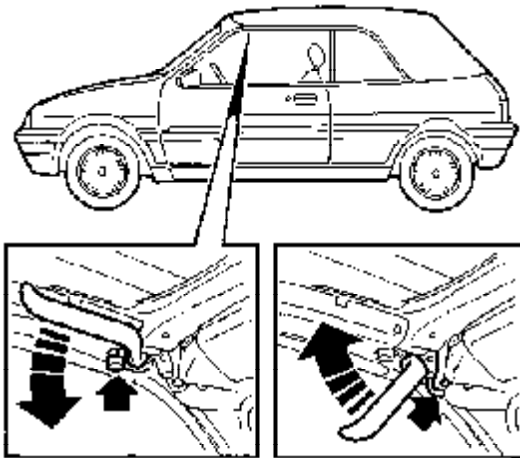

## Unlocking the Hood

Two locks secure the hood to the top of the windscreen.

1. Press up and hold the release button (arrowed), pull the locking handle down and forwards.
2. Pull down firmly with each locking handle to release the locking hook from its location in the top of the windscreen pillar.
3. When both hooks are released, push the locking handles back up to the roof.

## Opening the Hood

With the handbrake engaged and the starter switch turned to position 'II', press and hold the lower switch 'A', assist initial hood lift if necessary. The hood will move back and fold behind the rear seats. Release the switch as soon as the hood is fully open.

## WARNING!

For safety NEVER open or close the hood when the car is moving.

## Closing and Locking the Hood

Before attempting to close the hood, remove and stow the tonneau cover in the luggage compartment and **open both front and rear windows** two turns of the window handle. Press and hold the raise switch 'B', the hood will move forward to the closed position. Lock the hood in position as follows:

Press up and hold the release button, pull both locking handles down and forward as far as possible and engage the locking hooks in the holes at the top of the windscreen pillars. With the hooks securely engaged, push the handles up into the locked position parallel with the roof.

The windows can now be closed, thus ensuring that the window glass fits securely into the rubber seals of the hood.

# Hood

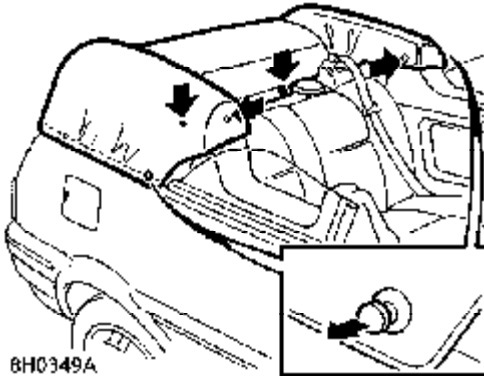
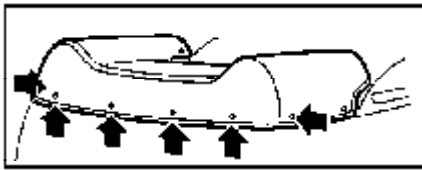

6H0349A

## Fitting the Tonneau Cover

Lay the tonneau cover loosely across the hood and pull down firmly into place.

Ensure the loose edges at the front of the tonneau cover fit neatly around the back of the seat belt anchorages and secure all tonneau fixings.

When not in use, store the tonneau cover in the luggage compartment in the bag provided.

## IMPORTANT INFORMATION

- NEVER open or close the hood when the car is moving, nor drive with the hood partially open, or with the locking handles unlocked.
- ALWAYS fit the tonneau cover before driving with the hood open - the cover is padded to protect rear passengers against accidental injury from the hood folding mechanism.
- Before opening or closing the hood make sure that all obstructions are removed and that passengers are warned to keep clear of any part of the hood while it is moving.
- When driving with the hood open, ALWAYS secure loose objects inside the car to prevent them from being blown out.
- DO NOT allow passengers to sit on the folded hood (even when the car is stationary).
- To prevent damage to the rear screen, DO NOT open or close the hood when the temperature is below 0° C (in sub-zero conditions the rear screen becomes brittle and susceptible to cracking when folded).
- DO NOT keep the hood open for longer than one week at a time.
- DO NOT drive with the rear screen open (exhaust fumes will be drawn into the car interior).
- DO NOT wash the Cabriolet in an automatic car wash or with high pressure water jets.
- DO NOT attach stickers to the rear screen.

# Hood

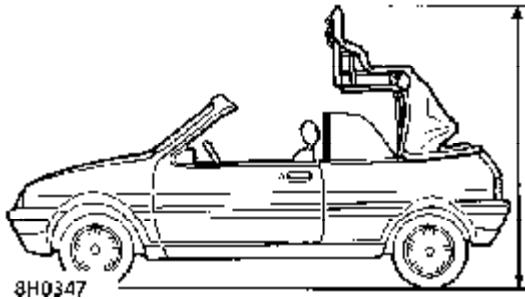

## Minimum Height

Ensure there is at least 2m headroom before opening or closing the hood.

## CLEANING AND CARING FOR THE HOOD

The rear screen is susceptible to scratching from the effects of dirt and grit. For this reason it is important to wash the screen frequently and to avoid opening or closing the hood when it is very dirty (see '**Cleaning and Care Care**').

If the car is to be parked in the open for long periods avoid parking it under trees.

## EMERGENCY OPERATION

In the event of an electrical fault, the power operated hood can be closed as follows:

1. Open the luggage compartment and lift the access panel as shown.
2. Turn the 'T' shaped screw four COMPLETE turns anti-clockwise.
3. It is now possible to close the hood manually. During manual operation the hood must NOT be moved at a pace significantly faster than that normally achieved during power operation.

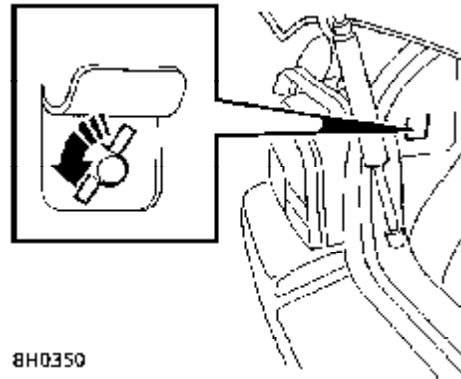

**Note:** To restore the roof to its normal power operated condition, fully retighten the 'T' shaped screw.



# *Interior Light & Clock*

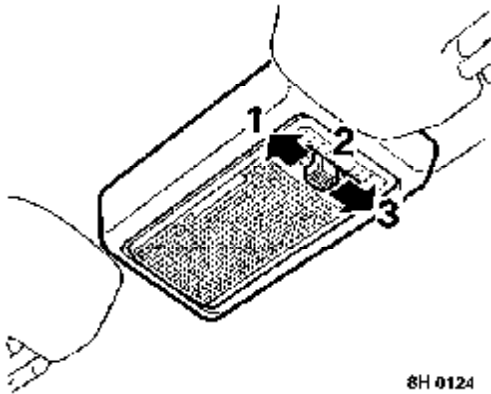

8H 0124

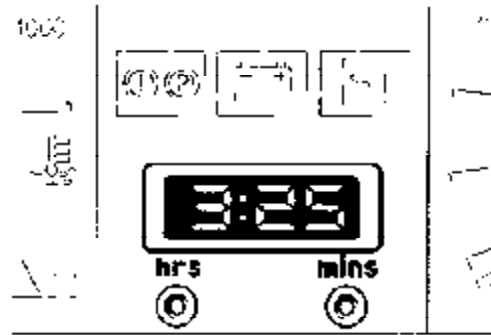

8H 0125A

## INTERIOR LIGHT SWITCH POSITIONS

1. Light Illuminates When a Door is Opened
2. Light Permanently Off
3. Light Permanently On

## CLOCK

The 12 hour clock display illuminates when the starter switch is turned to position 'I', and dims for night viewing when the side or headlights are on.

To adjust the clock, use a ball point pen or similar probe to press the 'hrs' and 'mins' time controls.

**Note:** The clock will need to be reset if the battery is disconnected.

# *Cigar Lighter & Ashtrays*

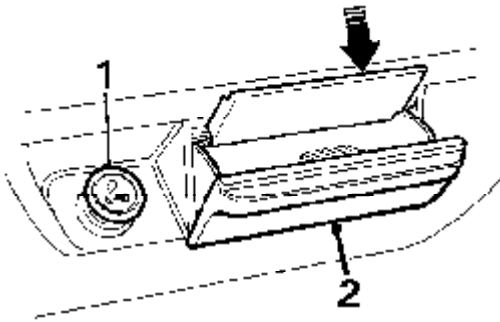

9H0137B

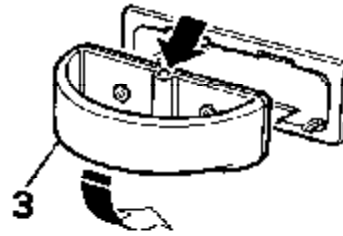

8H 0136

## **1. Cigar Lighter**

Push in centre of lighter to heat. When ready, the centre will eject and the lighter can be withdrawn for use.

## **2. Front Ashtray**

Open ashtray fully, hold cover down with thumb (arrowed in illustration) and pull down to remove.

To refit, place lower edge in position, hold cover down with thumb and push ashtray into the closed position.

## **3. Rear Ashtray**

To remove, open fully and press down to disengage top pivot pin (arrowed). Refit by first locating the bottom pivot and then easing the top pivot pin into place.

### **CIGAR LIGHTER**

Always hold the cigar lighter by the handle to avoid injury.

To avoid any risk of overloading the electrical circuit, accessories should not be plugged into the cigar lighter socket unless they are approved for this use.

**Note:** The cigar lighter only operates when the starter switch is turned to position 'I'.

### **ASHTRAYS**

Ashtrays are fire hazards - DO NOT use for waste paper or other combustible material.

# Load Carrying

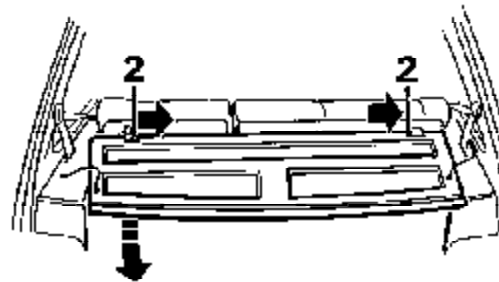
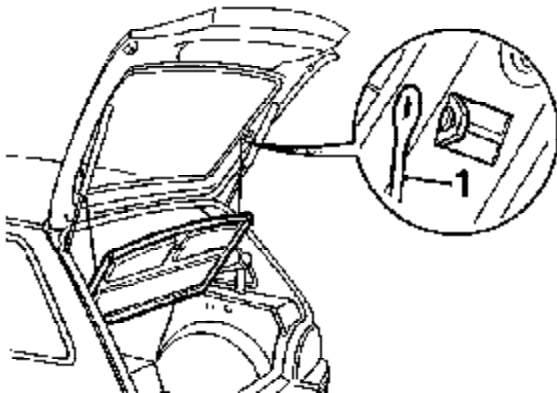

8H 0139A

1. Rear Shelf Lifting Straps
2. Rear Shelf Pivot Pins

## REAR WINDOW SHELF REMOVAL (not Cabriolet model)

Unhook the lifting straps, and push the shelf to the right until the left pivot pin is released from its retainer. The shelf can now be removed.

When refitting, first locate the pivot pin on the right side, push the shelf firmly to the right and ease the left pivot pin into position.

### WARNING!

Do not carry hard, heavy or sharply pointed objects on the rear window shelf - they could damage the window demisting element or become dangerous projectiles in the event of an accident or emergency braking.

## ROOF RACKS

It is **ESSENTIAL** that you only fit a roof rack designed and tested for your car. See your dealer for details of Rover approved roof racks.

The total roof rack load must **NEVER** exceed that given in '**Technical Data**', and must include the weight of the roof rack within the load. All loads should be evenly distributed, properly secured, and carried within the periphery of the roof rack.

### WARNING!

A loaded roof rack can reduce the stability of the vehicle, particularly when cornering and encountering crosswinds. Always reduce your speed to suit the conditions.

## TOWING CARAVANS AND TRAILERS

### Tow Bars

It is **ESSENTIAL** that you only fit a tow bar designed and tested for your car. Your dealer has details of all Rover approved towing equipment and can advise you of the most suitable type.

The permissible maximum towing weight and towing hitch load are given in '**Technical Data**'. In the interest of safety, these must not be exceeded!

# Load Carrying

## FOLDING THE REAR SEAT

### Saloon models

The backrest and seat cushion on some models are divided into two parts, either or both of which can be folded forward to increase the luggage area. A number of different seat configurations can be created and some are shown.

To release the rear seat backrest, press down the locking levers. These are shown 'arrowed' in the accompanying illustration and are best reached from inside the luggage compartment.

### Cabriolet model

Pull knob on LH side of luggage aperture to release rear seat backrest.

### Accommodating Long Loads

Remove the head restraint from the front passenger seat, move the front seat forward as far as possible and fully recline the backrest. Then remove the window shelf and press down the appropriate rear seat locking lever to enable a portion of the backrest to be folded forward as shown.

### Maximum Luggage Space

To create an extra large luggage carrying area:

1. Slide both front seats forward sufficiently to allow the whole of the rear seat to fold forward.
2. Unhook the window shelf lifting straps and release the rear seat backrest by pressing both locking levers down.
3. Fold the backrest forward allowing the window shelf to fold against the backrest, and tip the whole assembly forward as shown in the accompanying illustrations.

Before returning the rear seat to its normal upright position, remember to feed the seat belt locks through the gap between the backrest and seat cushion, and ensure the rear seat belts are not trapped behind the backrest. ALWAYS push the backrest firmly into place to fully engage the retaining locks.

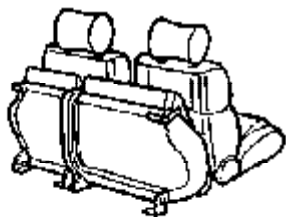
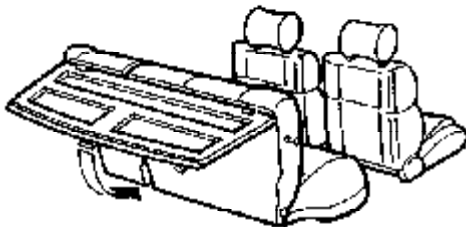
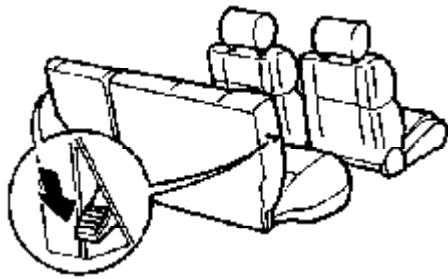

BH0202A

### WARNING!

Front seat passengers should never travel with the backrest reclined. Additionally, the rear seat backrest must always be locked in position when the seat is in use.



# *Identification Symbols*

---



























Most Rover controls, switches and instruments are marked with the international standard identification symbols shown below. However, please note that some symbols may not appear on your model.

## Warning Lights

The warning light symbols, when illuminated, identify the subject, while the colour defines the level of importance you should attach to the warning light.

**RED** - Warning **ORANGE** - Caution **BLUE or GREEN** - Unit operating



	Side and Headlights		Rear Screen Wash/Wipe		Oil Pressure
	Side Lights		Rear Screen Heater		Main Beam
	Dip Beam		Fog Lights		Rear Fog Guard
	Direction Indicators		Hazard Warning		Windscreen Wiper and Washer
	Rear Screen Wiper		High temperature/ Low coolant		Horn
	Handbrake/ Brake Fluid		Fuel Level/Fuel Filler Release		Glowplug
	Engine Temperature		Starting/No Charge		Bonnet Release
	Luggage Release		Heater Blower		Windscreen Demist/Defrost
	Cigar Lighter		Headlight Levelling		

# Driving Controls

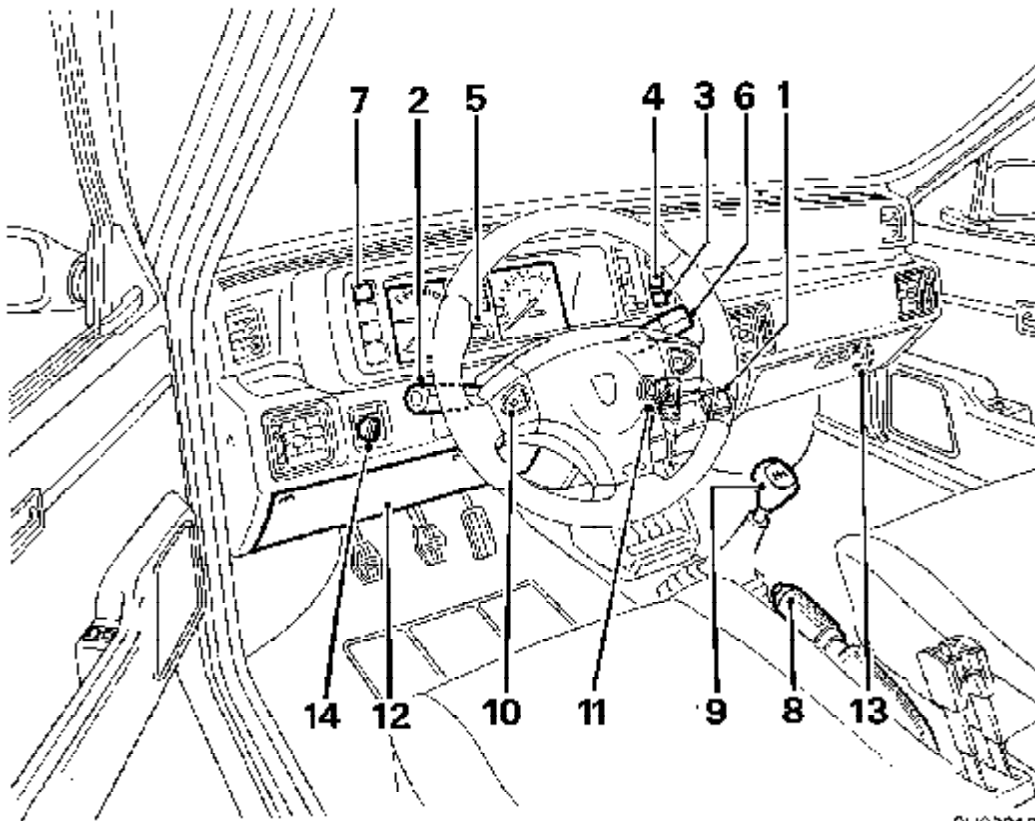

8H0201B

- |   |  |
|---|--|
| 1. Hazard warning lights switch                         | 8. Handbrake                                 |
| 2. Lighting and direction indicators switch             | 9. Gear lever                                |
| 3. Anti-theft alarm indicator - Germany only            | 10. Horn                                     |
| 4. Rear screen demister switch                          | 11. Starter switch/steering lock             |
| 5. Instrument and warning light panel                   | 12. Fuse box cover                           |
| 6. Windscreen and rear screen wipers and washers switch | 13. Bonnet release lever                     |
| 7. Rear fog guard lights switch                         | 14. Headlamp levelling switch - Germany only |

# Instruments & Warning Lights - Petrol

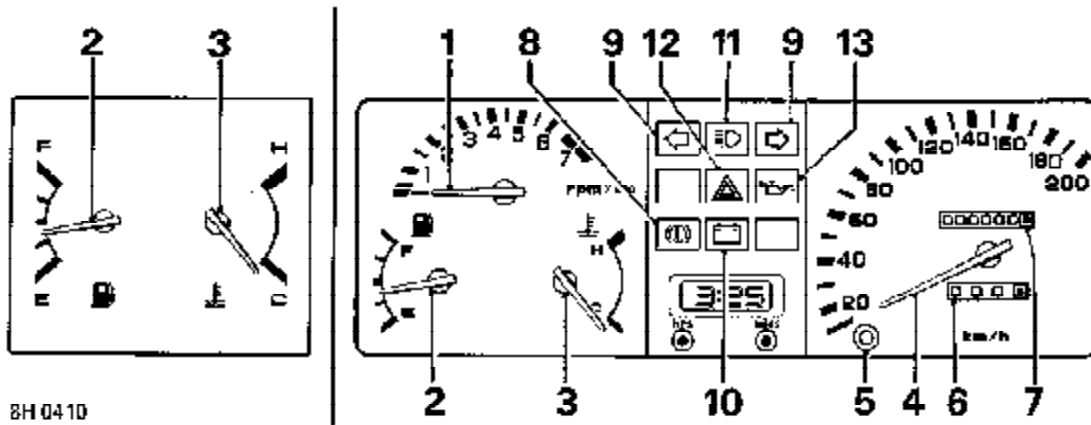

8H 04 10

Note: Instrument panel layout varies dependent upon model.

## INSTRUMENTS

- 1. Tachometer**  
Indicates engine speed in revolutions per minute. **NEVER allow the tachometer pointer to enter the RED sector.**  
**Note:** An automatic cut-off prevents the engine from exceeding 6,800 rev/min.
- 2. Fuel Gauge**  
The pointer indicates the fuel level even when the starter switch is turned off. After refuelling, the gauge slowly changes to the new level when the electrical circuits are switched on.
- 3. Temperature Gauge**  
Indicates engine coolant temperature. Once the engine is at normal operating temperature, the pointer should always remain between the 'C' (cold) and 'H' (hot) segments. If the pointer enters the HOT segment, stop the engine and seek qualified assistance.
- 4. Speedometer**
- 5. Trip Recorder Reset Button**  
Press to return trip recorder to zero.
- 6. Trip Recorder**  
Records individual journey distances.
- 7. Total Distance Recorder**  
Indicates the total distance travelled by the car.

## WARNING LIGHTS

- 8. Handbrake & Brake System**  
The light illuminates when the handbrake is applied and extinguishes when it is fully released. If the light illuminates while the handbrake is released, a fault with the braking system is indicated and you should seek qualified assistance urgently.
- 9. Direction Indicators**
- 10. Battery Charging**  
Light extinguishes when the engine is running. If it remains on, or lights whilst driving, a fault is indicated. Seek qualified assistance.
- 11. Headlight Main Beam**  
Illuminates when headlights are on main beam.
- 12. Hazard Warning Lights**
- 13. Low Oil Pressure**  
The light illuminates when the starter switch is turned on and extinguishes when the engine is started. If the light remains on or illuminates whilst driving, serious engine damage could occur. Stop the car as soon as safety permits and **SWITCH OFF THE ENGINE IMMEDIATELY.** Seek qualified assistance before driving.

# *Instruments & Warning Lights - Diesel*

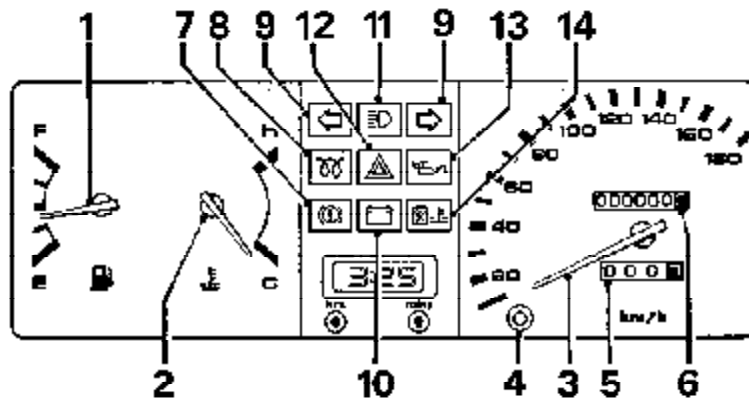

8H 0260B

## INSTRUMENTS

- 1. Fuel Gauge**  
The pointer indicates the fuel level even when the starter switch is turned off. After refuelling, the gauge slowly changes to the new level when the electrical circuits are switched on.
- 2. Temperature Gauge**  
Indicates engine coolant temperature. Once the engine is at normal operating temperature, the pointer should always remain between the 'C' (cold) and 'H' (hot) segments. If the pointer enters the HOT segment, stop the engine and seek qualified assistance.
- 3. Speedometer**
- 4. Trip Recorder Reset Button**  
Press to return trip recorder to zero.
- 5. Trip Recorder**  
Records individual journey distances.
- 6. Total Distance Recorder**  
Indicates the total distance travelled by the car.

## WARNING LIGHTS

- 7. Handbrake & Brake System**  
The light illuminates when the handbrake is applied and extinguishes when it is fully released. If the light illuminates while the handbrake is released, a fault with the braking system is indicated and you should seek qualified assistance urgently.
- 8. Glow Plug**  
Illuminates when the starter switch is turned to position 'II'. When the engine is cold, wait for the light to extinguish before starting the engine.
- 9. Direction Indicators**
- 10. Battery Charging**  
Light extinguishes when the engine is running. If it remains on, or lights whilst driving, a fault is indicated. Seek qualified assistance.
- 11. Headlight Main Beam**  
Illuminates when headlights are on main beam.
- 12. Hazard Warning Lights**
- 13. Low Oil Pressure**  
The light illuminates when the starter switch is turned on and extinguishes when the engine is started. If the light remains on or illuminates whilst driving, serious engine damage could occur. Stop the car as soon as safety permits and SWITCH OFF THE ENGINE IMMEDIATELY. Seek qualified assistance before driving.
- 14. Engine High Temperature & Low Coolant**  
If light illuminates whilst driving, a serious fault is indicated. Top-up the cooling system or seek qualified assistance.

# Starting & Driving

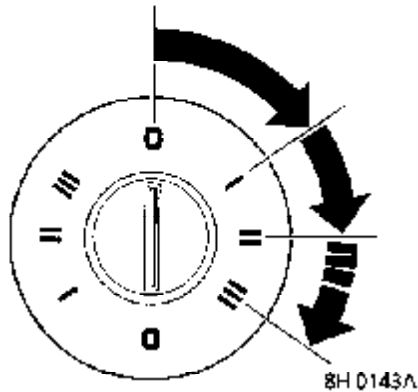

## STARTER SWITCH & STEERING LOCK

The combined switch uses the following sequence of key positions to operate the steering lock electrical circuits and starter motor:

### 'O' - Off

Electrical circuits switched off and steering locked (remove the key and turn the steering wheel slightly to engage the lock).

### 'I' - Steering Unlocked.

Turn the switch to position 'I' to unlock the steering. The radio/cassette player, cigar lighter and electric windows can now be operated.

### 'II' - Electrical Circuits On

All instruments, gauges, warning lights and electrical circuits operational.

### 'III' - Starter Motor Operates

Release the key as soon as the engine has started. The key will automatically return to position 'II'.

## STEERING LOCK

**To unlock the steering:** insert the key FULLY and turn to position 'I'- slight movement of the steering wheel will assist in disengaging the lock.

**To lock the steering:** turn the key to position 'O', withdraw the key and turn the steering wheel slightly until the lock engages.

**WARNING!** Once the lock is engaged, it is impossible to steer the car. For this reason the key must never be removed from the switch or returned to position 'O' while the car is in motion!

# *Starting & Driving - Petrol*

---

## **STARTING THE ENGINE**

Before starting, check that the handbrake is on and that the gear lever is in neutral. All unnecessary electrical equipment should be switched off.

Turn the starter switch to position 'III' to operate the starter motor and release the key as soon as the engine has started.

DO NOT press the accelerator pedal while starting and DO NOT operate the starter for more than 10 seconds at a time. If the engine fails to start; switch off and wait for 10 seconds before trying again.

**Note:** While starting in freezing conditions or when the battery is in a low state of charge, on manual gearbox cars reduce the load on the starter motor by depressing the clutch and holding it down until the engine is running.

## **Warming Up**

Drive the car as soon as the engine has started - DO NOT warm up the engine with the vehicle stationary.

Harsh acceleration or labouring the engine is not recommended at any time. However, when the engine is cold, this type of driving will damage the engine and must be avoided.

## **WARNING!**

Never start or leave the engine running in an unventilated building - exhaust gases are poisonous and contain carbon monoxide, which can cause unconsciousness and may even be fatal.

Catalytic converters are easily damaged through improper use, particularly if the wrong fuel is used, or if an engine misfire occurs - before starting the engine, you should be aware of the precautions detailed in the 'Catalytic converter' section of this handbook.

## **RUNNING-IN**

The engine, gearbox, brakes and tyres need time to 'bed-in' and adjust to the demands of everyday motoring. During the first 800 km it is essential that you drive with consideration for the running-in process and heed the following advice:

- ONLY operate the vehicle at moderate speeds.
- DO NOT operate at full throttle or allow the engine to labour in any gear.
- AVOID fast acceleration and heavy braking except in emergencies.

After the running-in distance has been completed, engine speeds may be gradually increased.



# *Starting & Driving - Diesel*

## **STARTING THE ENGINE**

Before starting, check that the handbrake is on and that the gear lever is in neutral. All unnecessary electrical equipment should be switched off.

### **Starting a Cold Engine**

- 1) Turn the starter switch to position 'II' and wait until the glow plug warning light goes out.
- 2) Without depressing the accelerator pedal, turn the starter switch to position 'III' to operate the starter motor and release the key as soon as the engine will run without starter assistance. DO NOT operate the starter motor for more than 10 seconds.
- 3) Allow the engine to idle for a few seconds before driving.

**Note:** While starting in freezing conditions, or when the battery is in a low state of charge, reduce the load on the battery by depressing the clutch and holding it down until the engine is running.

### **Starting a Warm Engine**

- 1) Whilst slightly depressing the accelerator pedal operate the starter motor immediately by turning the starter switch to position 'III'. Release the key as soon as the engine has started.
- 2) If the engine does not start at the first attempt, switch off, then turn the starter switch to position 'II' and wait until the glow plug warning light goes out before again attempting to start the engine.

**Note:** If the engine fails to start or starts but will not continue running, always turn the starter switch to the 'O' position and wait for 10 seconds before carrying out the warm engine start sequence 1 and 2.

## **RUNNING-IN**

The engine, gearbox, brakes and tyres need time to 'bed-in' and adjust to the demands of everyday motoring. During the first 1500 km it is essential that you drive with consideration for the running-in process and heed the following advice:

- ONLY operate the vehicle at moderate speeds.
- DO NOT operate at full throttle or allow the engine to labour in any gear.
- AVOID fast acceleration and heavy braking except in emergencies.

After the running-in distance has been completed, engine speeds may be gradually increased.

## **WARNING!**

Never start or leave the engine running in an unventilated building - exhaust gases are poisonous and contain carbon monoxide, which can cause unconsciousness and may even be fatal.

Catalytic converters are easily damaged through improper use, particularly if the wrong fuel is used or if an engine misfire occurs - before starting the engine, you should be aware of the precautions detailed in the 'Catalytic converter' section of this handbook.

# Catalytic Converter

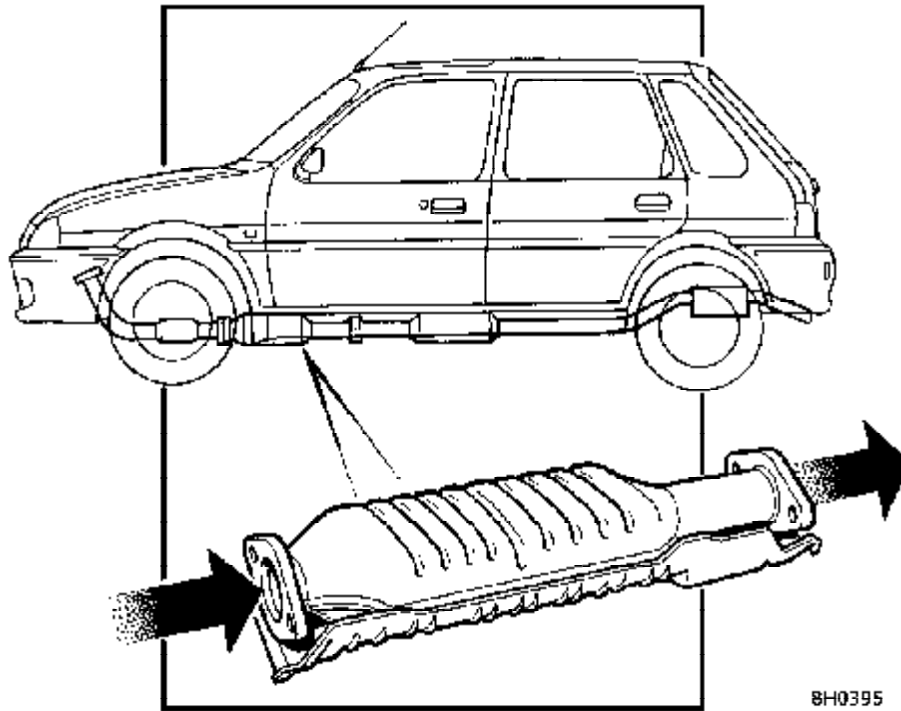

The exhaust system incorporates a catalytic converter, which converts poisonous exhaust emissions from the engine into environmentally less harmful gases, thereby reducing atmospheric pollution.

The catalytic converter can be easily damaged through improper use, particularly if the wrong fuel is used, or if an engine misfire occurs. For this reason it is **VERY IMPORTANT** that you heed the following precautions:

### ***Filling up with Fuel:***

- ONLY use fuel recommended for your car.

### ***Starting the Engine:***

- DO NOT continue operating the starter if the engine fails to start after a few attempts - seek qualified assistance.
- If a misfire is suspected when starting, DO NOT drive the car, or attempt to clear the misfire by pressing the accelerator pedal. Instead, turn the starter switch off immediately and seek qualified assistance.
- DO NOT attempt to push or tow start the car.

### ***Driving the Car:***

- Provided the engine has reached its normal operating temperature, if a misfire is suspected or the car lacks power while driving, it may be driven **SLOWLY** (at risk of catalyst damage) to a Rover dealer for assistance.
- NEVER allow the car to run out of fuel (the resultant misfire could destroy the catalyst).
- Engines burning excessive oil (blue smoke from the exhaust) will progressively reduce catalyst efficiency.
- On rough terrain do not allow the underside of the car to be subjected to heavy impacts which could damage the catalytic converter.
- DO NOT overload or excessively 'rev' the engine.

# *Catalytic Converter*

---

- DO NOT park on ground where combustible materials such as dry grass could come in contact with the exhaust system - in dry weather a fire could result.

## ***Vehicle Maintenance:***

- Any engine misfire, loss of engine performance or engine run-on, could seriously damage the catalytic converter. For this reason, it is vital that unqualified persons do not tamper with the engine, and that regular maintenance is carried out by a Rover dealer in accordance with the service interval plan included in the Service Portfolio book.
- DO NOT run the engine with a spark plug or HT lead removed, or use any device that requires an insert into a spark plug.

# Manual Gearbox

---

## MANUAL GEARBOX

Synchromesh engagement is provided on all forward gears, and in the neutral position the gear lever is spring loaded to rest naturally between 3rd and 4th gears.

### Reverse Gear

To select reverse gear, ensure the vehicle is stationary, and fully depress the clutch pedal, pausing briefly before moving the gear lever into the 'R' position.

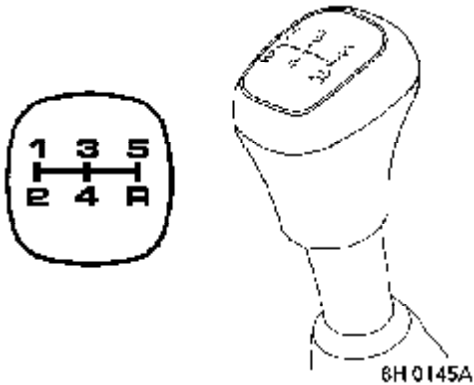

### WARNING!

Do not rest your hand on the gear lever while driving; pressure transmitted from your hand may cause premature wear to the gear selector mechanism.

Similarly, resting your foot on the clutch pedal whilst driving causes rapid wear to the clutch!



# Automatic Gearbox

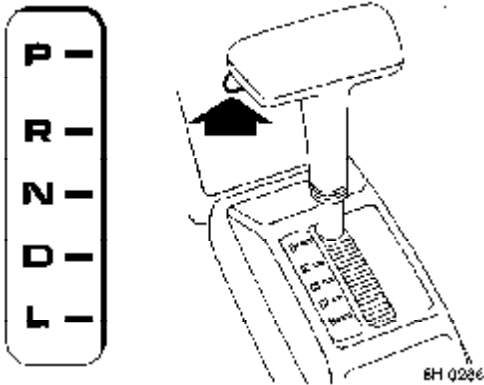

## CONTINUOUSLY VARIABLE TRANSMISSION

Your car is fitted with continuously variable transmission (CVT). This advanced design ensures a continuous and smooth progression from the lowest to the highest ratio (and vice versa), without the apparent gear changes associated with a conventional automatic gearbox.

## GEAR SELECTOR

### Selector Release Button

The automatic gearbox is fitted with a locking mechanism, designed to minimise the possibility of accidental selection of the 'P'(Park) and 'R' (Reverse) positions.

The selector release button (arrowed in illustration) must be pressed, in order to select 'P' or 'R' and also to enable the lever to be moved from the 'P' position.

## Selector Lever Positions

### 'P' - Park:

This position mechanically locks the transmission and should be selected before starting the engine and before switching the engine off. To avoid transmission damage, ensure the car is completely stationary, with the handbrake applied, before selecting 'P'.

The selector release button **MUST** be pressed, in order to move the selector lever into, or out of the Park position.

### 'R' - Reverse:

Before selecting reverse, **ENSURE** the car is stationary, with the brakes applied.

Press the selector release button in order to move the selector lever into reverse.

### 'N' - Neutral:

Select neutral when the car is stationary and the engine is required to idle for a brief period (at traffic lights for example). Always apply the handbrake.

### 'D' - Drive:

Select this position for all your normal driving; the transmission will adjust to the appropriate ratio, according to vehicle speed and accelerator position.

### 'L' - Low:

Low ratio can be selected at any speed, in order to provide additional engine braking when the accelerator pedal is released.

# Automatic Gearbox

---

## **WARNING!**

DO NOT select 'P' or 'R' unless the car is stationary.

To prevent transmission wear, keep engine speed as low as possible while moving the selector between 'D' and 'R'.

DO NOT select 'D' or 'L' when the car is moving backwards.

DO NOT press the selector release button, while selecting 'N' from a forward or reverse drive position.

## **USING THE AUTOMATIC GEARBOX**

The following information is particularly important for drivers who are unfamiliar with the techniques required to drive cars with automatic transmission.

### **Starting**

The engine can only be started with the selector lever in the 'P' or 'N' positions.

- ALWAYS apply the handbrake and foot brake before starting the engine.
- KEEP BOTH BRAKES APPLIED while moving the selector to a drive gear position.
- DO NOT 'rev' the engine or allow it to run above normal idle speed while selecting a forward or reverse gear, or while the car is stationary with a drive gear already selected.
- ALWAYS keep the brakes applied until you are ready to move off - remember, once a drive gear has been selected, an 'automatic' will tend to creep forward (or backward).
- DO NOT allow the car to remain stationary for any length of time, with a drive gear selected and the engine running (always select 'N' (Neutral), if the engine is to idle for a prolonged period).

### **Driving**

When driving, the transmission will automatically adjust to the most appropriate ratio, according to accelerator position, vehicle speed and terrain (whether the car is driving uphill, downhill or on the flat).

When accelerating, the engine speed will increase above the equivalent road speed, as the transmission adjusts to the most appropriate ratio. When the accelerator pedal is released, engine speed will drop independently of road speed.

## **WARNING!**

When driving in reverse gear, engine speed must be kept to a minimum.

### **Parking**

After bringing the car to a stop, ALWAYS apply the handbrake and select 'P', before releasing the foot brake and switching off the engine.

### **Freeing the Car from Snow or Mud**

With the engine idling, select 'D' or 'R' and increase engine speed very slightly, making sure the front wheels do not spin. If the wheels do spin, use minimum engine speed to regain grip. If unsuccessful, engage 'D' or 'R' alternately and use minimum engine speed until grip is regained.

## **WARNING!**

Cars fitted with automatic transmission can NOT be 'push' or 'tow' started.



# Lights & Indicators

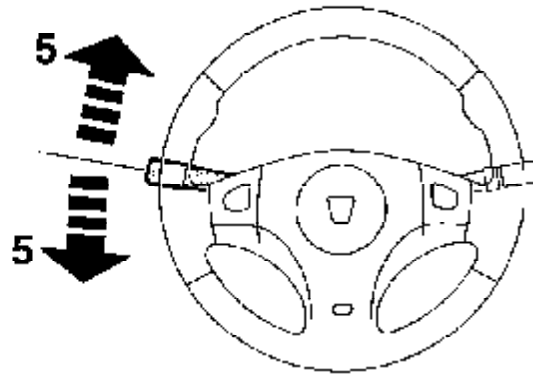
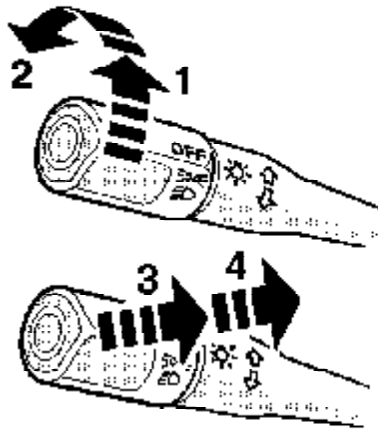

8H0454

- 1. Side, Tail and Panel Lights**  
Rotate switch to Position 1.
- 2. Headlights**  
Rotate switch to Position 2.
- 3. Headlight Flasher**  
Flick lever briefly towards the steering wheel and release.
- 4. Headlight Main and Dipped Beams**  
Pull lever fully towards the steering wheel to change headlight beams (the blue warning light glows whenever the headlights are on main beam).
- 5. Direction Indicators**  
Move the lever down to operate left-hand indicators, and up to operate right-hand indicators.  
Hold lever half-way up or down against spring pressure to indicate a lane change.

## USING YOUR LIGHTS

### Lights On Warning Buzzer

If any exterior lights are left on when the electrical circuits are switched off, a warning buzzer will sound as soon as the driver's door is opened. The buzzer will cease when the lights are switched off or the driver's door is closed.

### Headlights on Main Beam

Take care not to dazzle other road users. Never use headlights on main beam in the face of on-coming traffic or when closely following another vehicle.

## Headlight levelling (German Markets only)

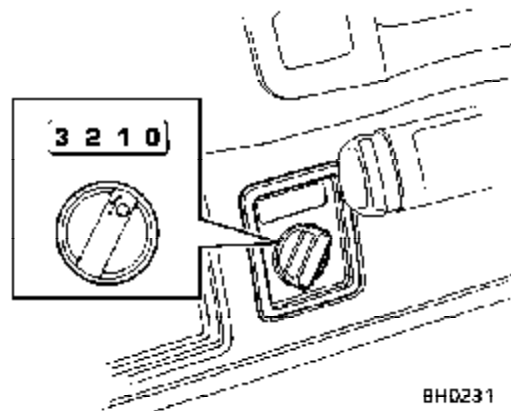

8H0231

The position of the headlights can be adjusted according to vehicle loading as follows:

Switch position	Vehicle load
0	Driver + up to three passengers
1	Driver + four passengers
2	Driver + four passengers and luggage up to max. load
3	Driver only + luggage up to max. load

# Switches

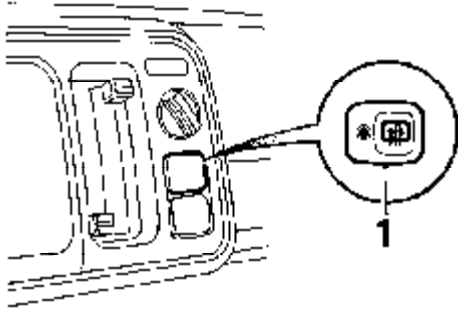

9F 0196

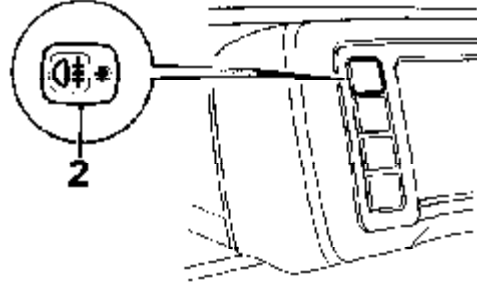

HH 0196

## 1. Rear Screen Demister

Press to operate - AMBER light will glow. Press again to switch off when rear screen is clear.

**Note:** The demister will only operate with the starter switch at position 'II'.  
DO NOT stick labels over the heating elements in the rear screen.

## 2. Rear Fog Guard Light

Press to operate - AMBER light will glow. Use ONLY when normal visibility is severely restricted by fog or mist. Remember to switch off - the fog guard light will dazzle other road users in clear conditions!

**Note:** The fog guard light operates only with the headlights switched on.

## HAZARD WARNING LIGHTS

Press to operate all the direction indicators together. Use ONLY in an emergency to warn other road users when your vehicle is causing an obstruction or is in a hazardous situation.

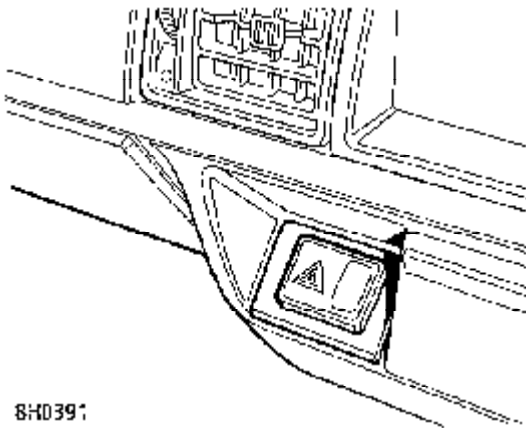

8H0391

## HORN

*Airbag equipped models:*

The horn is sounded by pressing one of the horn pushes either side of the steering wheel centre pad.

*Models without airbag:*

The horn is sounded by pressing the centre pad of the steering wheel.

Use the horn to warn pedestrians and other road users of your presence - particularly when approaching 'blind' corners and on narrow, twisty roads.



# Wipers & Washers

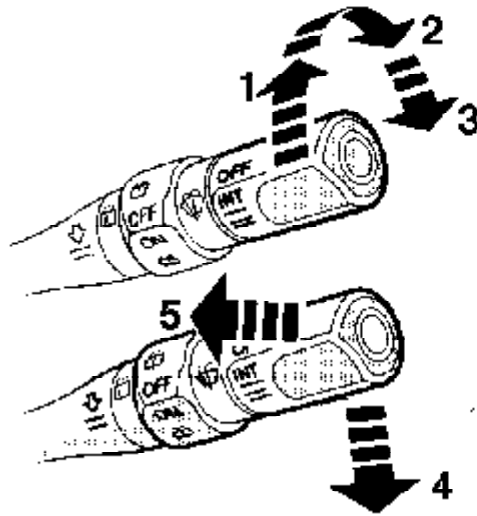

## WINDSCREEN WIPERS AND WASHERS

- 1. Intermittent Wipe**  
Rotate the switch to Position 1 - wipers operate every five seconds approx.
- 2. Normal Speed Wipe**  
Rotate the switch to Position 2.
- 3. Fast Speed Wipe**  
Rotate the switch to Position 3.
- 4. Single Wipe**  
Move the lever down and release.
- 5. Windscreen Wash/Wipe**  
Pull the lever towards the steering wheel and hold for duration of wash/wipe. After the lever is released, the wiper will continue operating for a further five seconds.

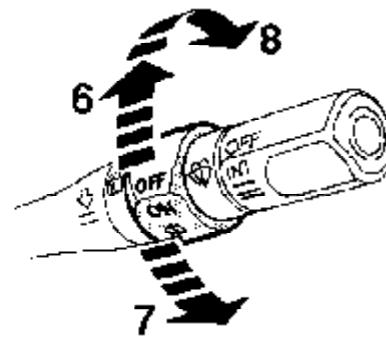

## REAR SCREEN WIPER AND WASHER

- 6. Rear Screen Wiper**  
Rotate switch to Position 6. After continuously wiping for eight seconds approx. the wiper operates intermittently.
- 7. Rear Screen Wash/Wipe**  
Rotate switch backwards to position 7 and hold for duration of wash/wipe. After control is released wiper operates for about eight seconds before switching off.
- 8. Rear Screen Intermittent Wash/Wipe**  
Rotate switch forward to position 8 and hold for duration of wash/wipe. After control is released, wiper operates for about eight seconds, and then wipes intermittently until switched off.

## OPERATING THE WIPERS AND WASHERS

To protect the wipers from premature wear, they should not be operated on a dry screen. In freezing or very hot conditions, you should ensure that the blades are not frozen or otherwise stuck to the

glass. In winter, remove accumulations of snow or ice from around the wiper arms and blades, including the wiped area of the windscreen and the heater air intakes and surrounds.

# Brakes

---

## **BRAKING SYSTEM**

The hydraulic braking system operates through two, diagonally split circuits - each controlling one front and one rear wheel. If one circuit should fail, the other will continue to function, but this will result in increased brake pedal travel and longer stopping distances.

Always remember, the brakes are servo assisted. If the engine stops, this assistance will be lost, requiring greater pedal effort and resulting in longer stopping distances.

### **Brake Pads**

Brake pads and shoes require a period of bedding in. For the first 800 km, you must avoid situations where heavy braking is required.

Overheating reduces the efficiency of the brake pads. When descending steep hills select a lower gear to reduce the braking effort.

Remember that regular servicing is vital to ensure that the brake components are examined for wear at the correct intervals and changed whenever necessary to ensure optimum safety and performance.

### **Brake Warning Light**

If the warning light comes on when driving, and the handbrake is fully released, a fault is indicated. This is most likely to be caused by low fluid level, or worn brake pads and linings; stop the car and seek qualified assistance before continuing.

### **Driving in the Wet**

Driving in very wet conditions - through surface water or snow covered roads - can severely wet the brake components, reducing braking efficiency. In these conditions, drive with great care and frequently dry the pads or shoes by gently applying the brakes whenever it is safe to do so.

## **HANDBRAKE**

The handbrake operates on the rear wheels only. Pull the lever up to operate.

To release, pull the lever up slightly, depress the button and lower the lever.

If the handbrake travel becomes excessive, or the brake fails to hold the car, consult your Dealer.

Apply the handbrake fully whenever you park and, as an additional precaution, select 1st gear to prevent any possibility of the car moving.

### **WARNING!**

- DO NOT rest your foot on the brake pedal while driving; this may overheat the brakes, reducing their efficiency and causing excessive wear.
- If the brake warning light illuminates while driving, stop the car as soon as safety permits and seek qualified assistance before continuing.
- NEVER move the car without the engine running - servo assistance may be lost; the brakes will still function, but greater pedal pressure will be required.



# Fuel System

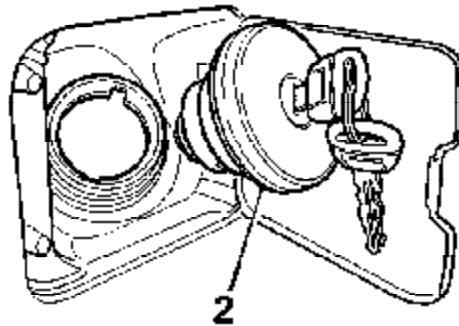
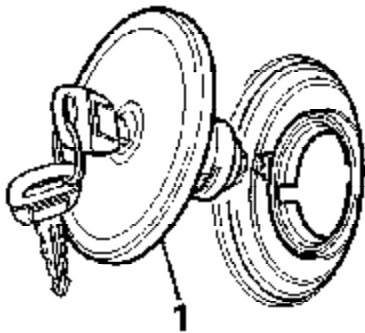

8F.015Z

## 1. Fuel Filler Cap (3 door models)

Turn key a quarter turn to the left to unlock and remove the cap.

## 2. Fuel Filler Cap (5 door models)

Open flap, turn key a quarter turn anti-clockwise to unlock and remove the cap.

### TYPE OF FUEL

#### PETROL:

Use only unleaded fuel as follows:

*Premium UNLEADED - 95 RON minimum to EN 228 specification*

#### WARNING!

**NEVER USE LEADED FUEL IN A CAR FITTED WITH A CATALYTIC CONVERTER. (serious damage will occur!)**

#### ALSO

**DO NOT use fuel of a lower RON (Research Octane Number) than that specified above.**

#### DIESEL:

Use only diesel fuel (also known as Automotive Gas Oil) to EN 590 specification.

**WARNING!** If the fuel tank is accidentally filled with petrol it is essential you contact your dealer for advice BEFORE starting the engine.

### FUEL FILLING

The pump filler nozzle should be inserted up to approximately half its length into the fuel tank filler tube. DO NOT try to fill the tank quickly and only fill the tank until the filler nozzle automatically cuts/shuts off. DO NOT fill the tank beyond this point, or spillage could result. Always refit the cap securely.

#### Petrol Cars

The filler tube on petrol cars is designed to only accept a narrow filler nozzle of the type found on pumps that deliver solely UNLEADED fuel. A flap lies across the entrance to the filler neck. Always insert the filler nozzle sufficiently to fully open the flap before filling.

#### Diesel Cars

The fuel filling system used for car commercial pumps is designed to fill at a maximum of 45 litres per minute. Use of pumps with a higher fill rate will result in premature pump cut-off and fuel spillage.

# Fuel System

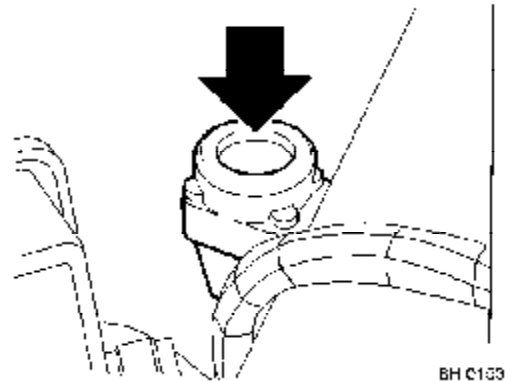
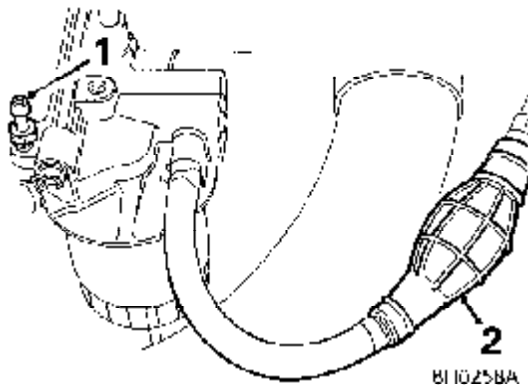

## EMPTY FUEL TANK

### Petrol Cars

Never allow the car to run out of fuel - the resultant misfire will destroy the catalytic converter.

### Diesel Cars

First refuel the tank, then unscrew the fuel filter bleed screw (1 in illustration above) three quarters of a turn. Expel air from the fuel system by depressing the priming bulb (2) several times until fuel is discharged from the bleed screw. Finally, retighten the bleed screw.

During this process fuel spillage will occur at the bleed screw. **Take precautions to prevent the fuel from soiling other engine components.**

## FUEL CUT-OFF SWITCH (Petrol engine cars only)

The fuel cut-off switch is a safety device which, in the event of a collision or sudden impact, automatically cuts off the fuel supply.

The switch is located in the left side of the engine compartment near the heater air duct. After an impact, the switch must be reset by pressing the rubber top (arrowed in illustration) before the engine can be restarted.

**ALWAYS check for fuel leaks before resetting the switch!**

## WARNING!

Petroleum gases are highly inflammable and in confined spaces are also explosive. Always take sensible precautions when refuelling:

- Switch off the engine.
- Do not smoke or use a naked flame or light.
- Take care not to spill fuel.
- Do not overfill the tank.

# *Fuel System*

---

## **FUEL ECONOMY**

To obtain the best fuel economy your engine must be correctly tuned and the car maintained in accordance with the manufacturer's recommendations. Other items such as tyre pressures and wheel alignment can also have a significant effect on fuel consumption.

Above all, the way in which the car is driven is most important, and the following hints may help YOU to obtain even better value from your motoring:

- Avoid unnecessary short, start-stop journeys
- Avoid fast starts and always accelerate smoothly.
- Do not drive in low gears longer than necessary.
- Anticipate obstructions, and adjust your speed well in advance.
- Ensure tyre pressures are correct, and remove a roof rack when not in use.
- Decelerate gently and avoid sudden or heavy braking.

**DRIVING GENTLY SAVES FUEL!**

# Maintaining Your Car

The safe, reliable performance of your car will depend largely on how well it is maintained.

Maintenance is the owner's responsibility and you should ensure that all routine services and anti-corrosion warranty inspections are carried out by a Rover dealer at the recommended intervals. These are shown in the Service Portfolio Book included in the literature pack. This book also provides a complete record of the services and inspections carried out on your car - you should ensure that your Rover dealer has correctly endorsed the appropriate page at the conclusion of each service.

## OWNER MAINTENANCE

In addition, the following simple checks should be carried out between services. You can do these yourself and advice is given on the pages that follow.

### Daily Checks:

- Check operation of lights, horn, direction indicators, wipers, washers and warning lights.
- Check operation of seat belts and brakes.
- Look out for deposits on the floor beneath the car which may indicate a fluid leak.
- Engine oil level (diesel models).

### Weekly Checks:

- Engine oil level (petrol models).
- Screen washer reservoir level.
- Condition and pressure of tyres.
- Cooling system level.
- Brake fluid level.

**Note:** Any significant or sudden drop in fluid levels, or uneven tyre wear should be reported to your dealer without delay.

## SAFETY IN THE GARAGE

**If you need to carry out maintenance on your vehicle, the following safety precautions should be observed at all times:**

- ALWAYS keep hands, tools and items of clothing clear of all drive belts and pulleys. (Remember, the cooling fan may operate even though the engine is not running).
- DO NOT touch exhaust or cooling system components until they are cool.
- DO NOT touch electrical leads or components with the starter switch on.
- NEVER leave the engine running in an unventilated area - exhaust gases contain carbon monoxide which is poisonous and extremely dangerous.
- DO NOT work beneath the car with the vehicle lifting jack as the only means of support.
- Ensure sparks and naked lights are kept away from the engine compartment.
- Remove metal wrist bands and jewellery before working in the engine compartment and NEVER allow battery terminals or leads to contact tools or metal parts of the car.

### Poisonous Liquids

Most liquids used in motor vehicles are poisonous and should not be consumed or brought into contact with open wounds. These substances include; acid, anti-freeze, brake and power steering fluid, petrol, diesel, oil and windscreen washer additives.

Obey all instructions printed on labels and containers!

### Used Engine Oil

Prolonged contact with engine oil may cause serious skin disorders, including dermatitis and cancer of the skin. Wash thoroughly after contact.

### PROTECT THE ENVIRONMENT!

It is illegal to pollute drains, water courses or soil. Use authorised waste disposal sites and garages providing facilities for the receipt of discarded batteries, used oil and toxic chemicals. If in doubt contact your local authority for advice.



# Engine Compartment

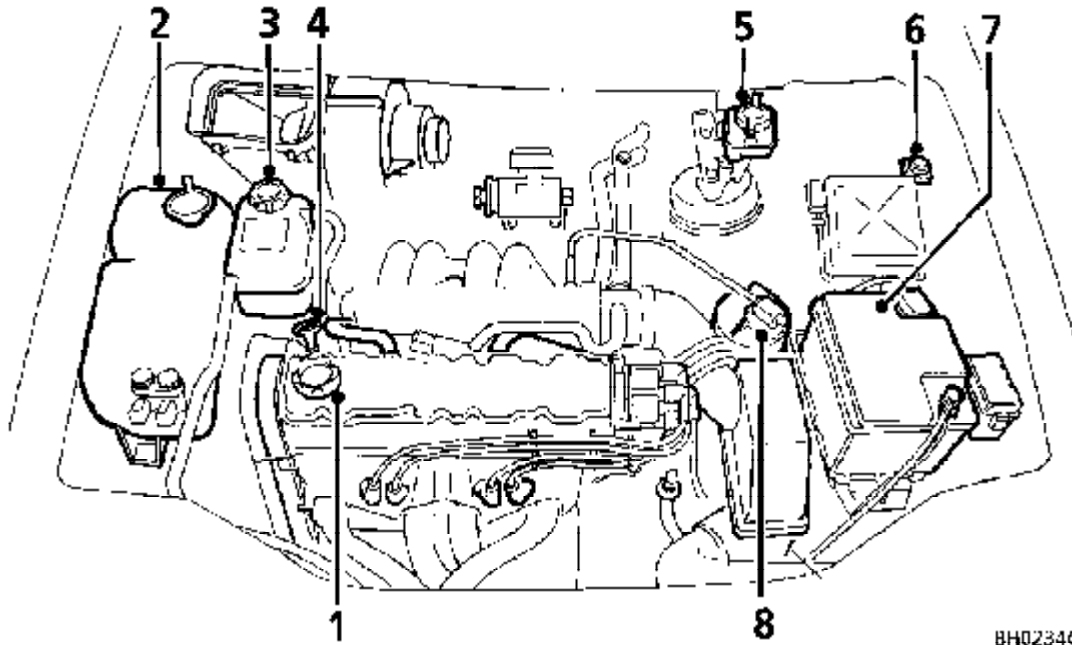

BH0234C

## **PETROL**

- |                                |                          |
|--------------------------------|--------------------------|
| 1. Engine oil filler cap       | 5. Brake fluid reservoir |
| 2. Windscreen washer reservoir | 6. Fuel cut-off switch   |
| 3. Cooling system reservoir    | 7. Battery               |
| 4. Engine oil dipstick         | 8. Charcoal canister     |

# *Engine Compartment*

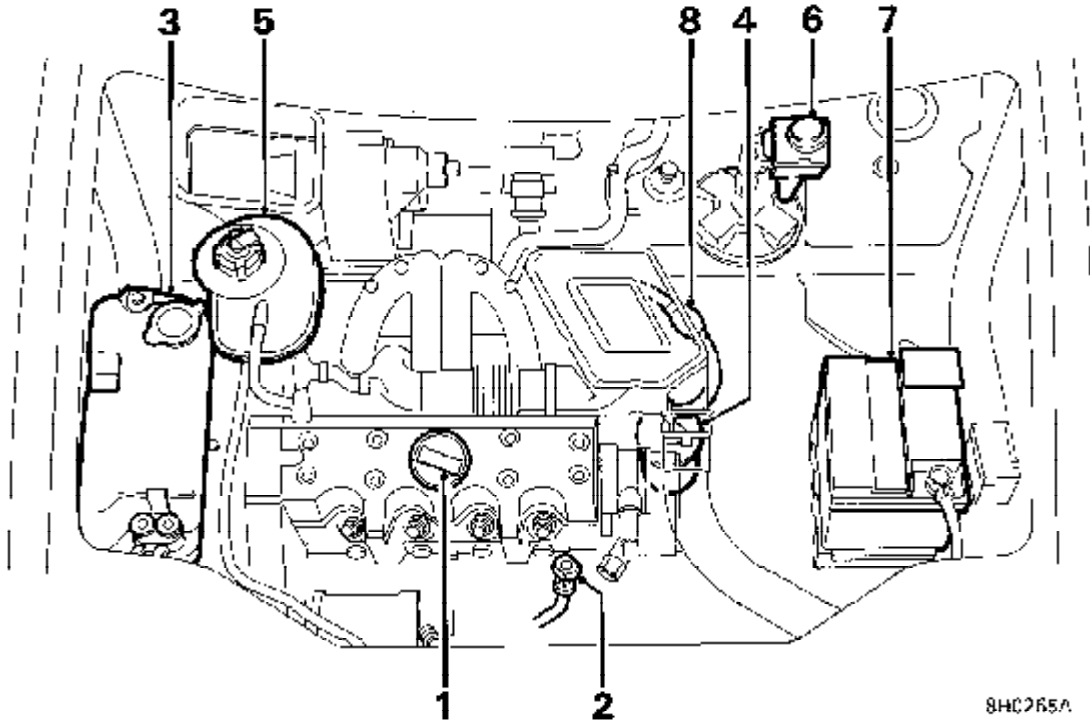

8HC265A

## **DIESEL**

- |                                |                             |
|--------------------------------|-----------------------------|
| 1. Engine oil filler cap       | 5. Cooling system reservoir |
| 2. Engine oil dipstick         | 6. Brake fluid reservoir    |
| 3. Windscreen washer reservoir | 7. Battery                  |
| 4. Fuel filter                 | 8. Fuel system priming bulb |

# Bonnet Opening

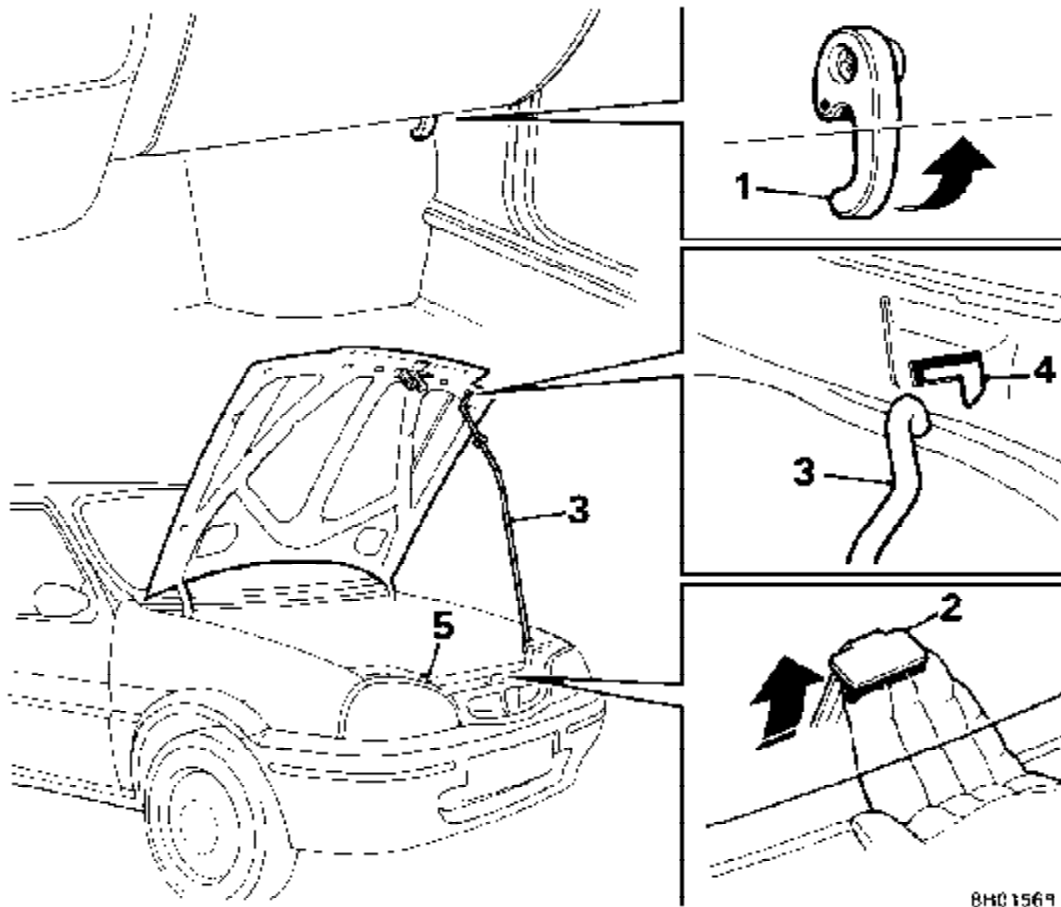

8H01569

**1. Bonnet Release Handle**

Pull handle to release bonnet latch.

**2. Bonnet Safety Catch lever**

Lift lever to release safety catch.

**3. Bonnet Support Stay**

Fit into 'arrowed' cut-out in the bonnet.

**4. Support Stay Cut-out**

**5. Support Stay Stowage Clip**

## CLOSING THE BONNET

Stow the support stay in its clip, then lower the bonnet, allowing it to drop for the last 150 millimetres approx. Check that the lock is FULLY engaged by attempting to lift the front edge of the bonnet, which should be free from all movement.

### WARNING!

Do not pull the bonnet release handle when the car is moving, nor drive with the bonnet unlatched and retained by the safety catch alone.

# Engine

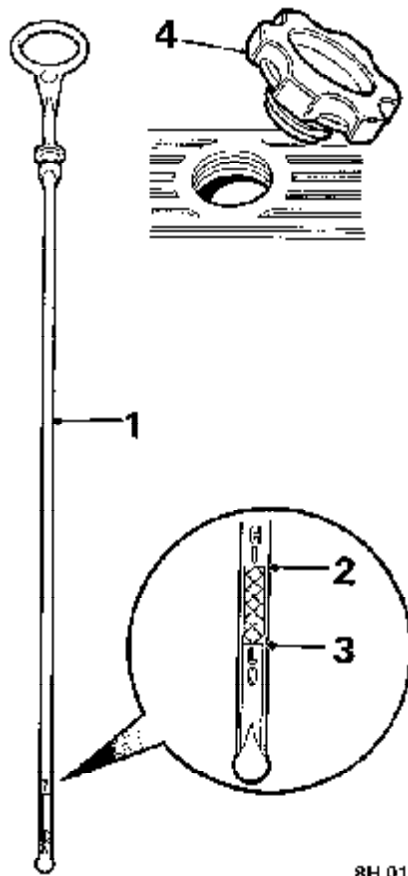

*Petrol Engines*

- 1. Oil Level Dipstick**  
Pull to remove.
- 2. Oil Level Maximum Mark**
- 3. Oil Level Minimum Mark**
- 4. Oil Filler Cap**  
Unscrew to remove.

### **OIL LEVEL TOPPING-UP**

**For petrol engines:**  
*Check the oil level every week.*

**For Diesel engines:**  
*Check the oil level every day.*

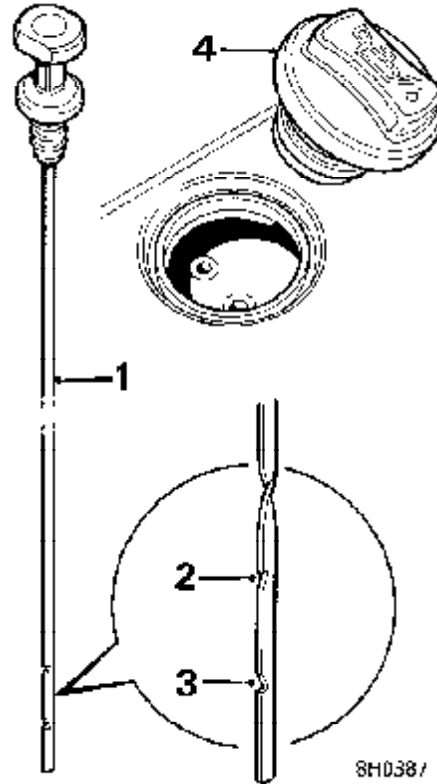

*Diesel Engines*

The engine oil level must be maintained between the minimum and maximum marks. With the engine cold and the car resting on level ground, withdraw the dipstick and wipe the blade clean. Re-insert the dipstick and withdraw again to check the oil level.

To top-up, unscrew the oil filler cap and add sufficient oil to bring the level to the dipstick maximum mark. Use the correct grade of oil and **DO NOT OVERFILL!** (excess oil can reduce performance and interfere with the engine ventilation system).

**Quantity of oil required to raise level from 'MIN' to 'MAX':**

Petrol engines: 1.0 litre  
Diesel engines: 2.0 litre



# Engine & Heater Duct

## Oil Specification

### Petrol engines:

Use ONLY a well known brand of 10W/40 engine oil meeting the specification *RES. 22.OL.G4* or *ACEA A2:96*, or *API SG*, or *API SH*.

### Diesel Engines:

Use only a well known brand of 10W/40 or 15W/40 engine oil meeting the specification *RES.22.OL.PD2* or *ACEA B2:96*.

Oils within this specification are suitable for use in the temperature range -20° C to +30° C.

For continual operation in climates where temperatures usually exceed or fall below these limits, seek advice from your dealer.

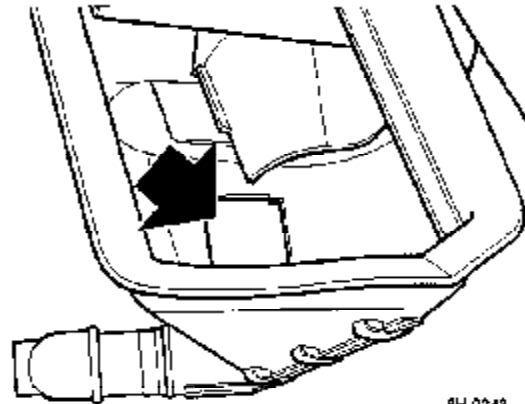

8H 0243

## Heater Duct

Open the bonnet and ensure that the heater duct drain is clear of any obstruction.

# Cooling System

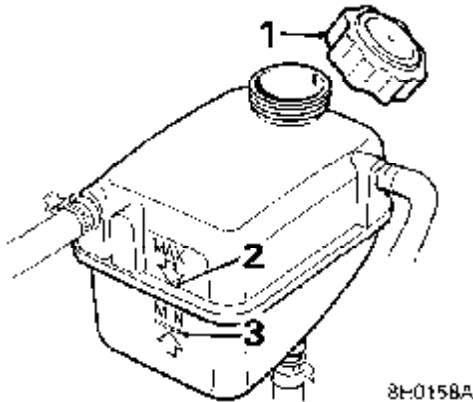

*Petrol Engines*

- 1. Filler & Pressure Relief Cap**  
Turn anti-clockwise to remove (ONLY when the system is cold).
- 2. Maximum Level Indicator**  
Top-up to this level.
- 3. Minimum Level Indicator**  
Top-up coolant if level falls below indicator.

## COOLING SYSTEM TOP-UP

The coolant level should be maintained between the maximum and minimum indicators **WHEN THE SYSTEM IS COLD**.

Check the level weekly and if more coolant is needed, add a 50% anti-freeze/water mixture.

Always wait until the system is cold and unscrew the filler cap slowly to gradually release any pressure in the reservoir. If the level has fallen appreciably below the minimum indicator, particularly over a short period, suspect leakage or overheating and arrange for your dealer to examine the vehicle.

### WARNING!

- NEVER remove the filler cap when the cooling system is hot - injury can result from escaping steam or water.
- Take precautions to prevent anti-freeze coming in contact with the skin or eyes. If this should happen, rinse immediately with plenty of water.

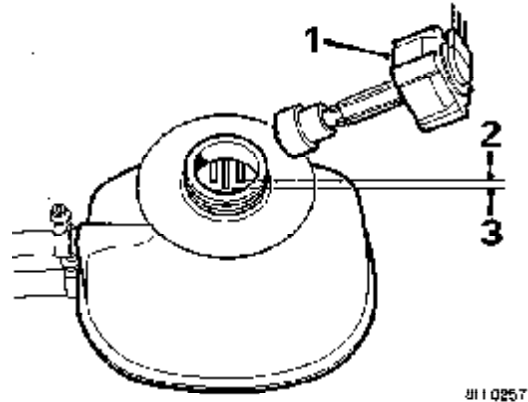

*Diesel engines*

### Anti-freeze

The cooling system was filled with the correct mixture of anti-freeze and water when the car was delivered new. Anti-freeze not only prevents the water from freezing in frost conditions but also ensures maximum corrosion prevention and, therefore, must be maintained throughout the life of the car.

The anti-freeze content should not be allowed to fall below 50% and must not exceed 60%. This should be checked by your dealer each year.

We recommend you use **Unipart Superplus 3 Anti-freeze and Summer Coolant**. If this is not available, use an ethylene glycol based anti-freeze, containing no methanol and with non-phosphate corrosion inhibitors which meets specifications BS 6580 and BS 5117.

### WARNING!

DO NOT use anti-freeze to any specification other than that indicated above, or add rust inhibitors or other additives to the coolant - these may not be compatible with the coolant or engine components.



# Braking System

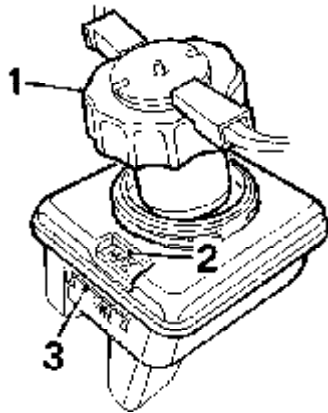

8r 9159

- 1. Reservoir Filler Cap**  
Turn anti-clockwise to remove.
- 2. 'MAX' - Maximum Level**
- 3. 'MIN' - Minimum Level**

## WARNING!

- DO NOT drive the car if the fluid level is below the 'MIN' mark.
- Brake fluid will damage painted surfaces: soak up any spillage with an absorbent cloth immediately and wash the area with a mixture of car shampoo and water.
- If brake fluid should come into contact with the skin or eyes, rinse immediately with plenty of water.
- Brake fluid must be completely replaced every two years regardless of mileage.

## BRAKE FLUID LEVEL

The fluid level will fall slightly as a result of normal pad wear, and should be checked every month. If the fluid has dropped below the 'MIN' mark or there has been an appreciable drop in level over a short period, consult your Dealer immediately.

## Topping-up

Always prevent dirt from entering the reservoir by wiping the filler cap clean before removing, and top-up to the 'MAX' mark using one of these recommended fluids:

*AP New Premium Super DOT 4 brake fluid.*  
*Castrol Universal DOT 4 brake fluid.*

When screwing or unscrewing the cap, hold the centre terminal block stationary to avoid disturbing the electrical connections.

Use only new brake fluid from an airtight container (brake fluid from uncapped containers absorbs moisture and may reduce braking performance).

# Tyres

## CARING FOR YOUR TYRES

Always drive with consideration for the condition of the tyres, and frequently inspect the tread and side walls for signs of distortion (bulges), cuts or wear.

The most common causes of tyre failure are:

- Bumping against kerbs
- Driving over deep potholes
- Driving with under or over-inflated tyres
- Driving on unmetalled roads



### **WARNING!**

**DEFECTIVE TYRES ARE DANGEROUS!**

DO NOT drive your car if any tyre is damaged, excessively worn, or is inflated to an incorrect pressure.

Incorrectly specified tyres can affect the stability and handling characteristics of your car - fit **ONLY** replacement tyres that are identical to the original specification.

### **Tyre Pressures**

Correctly inflated tyres will enable you to obtain the best combination of tyre life, ride comfort, fuel economy and road handling.

Check the pressures weekly - including the spare - preferably when the car has not been driven and the tyres are cold.

You should be aware that air pressure naturally increases as tyres become warm. The recommended pressures shown in '**Technical Data**' at the rear of the book are for **COLD TYRES ONLY**. If it is necessary to check the tyres when they are warm (tyres become warm after the car has been driven for 1.6 km or more - even in cold weather), you should expect the pressures to have increased by between 0.3 to 0.4 bar.

When the tyres are warm, **NEVER** let air out of the tyres in order to match the recommended pressures.

Remember; incorrectly inflated tyres wear rapidly and may seriously affect the car's road handling characteristics and fuel economy.

### **Wear Indicators**

Your tyres have wear indicators moulded into the tread pattern at several points around the circumference. When the tread has worn down to 1.6 mm, the indicators will come to the surface of the tread pattern, producing the effect of a continuous band of rubber across the width of the tyre.

The indicators provide warning that there is insufficient tread remaining to provide adequate traction. For safety, a tyre **MUST** be replaced as soon as a wear indicator becomes visible.

If tyre wear is uneven (on one side of the tyre only), or becomes abnormally excessive, the wheel alignment should be checked by your dealer.

### **Valve Caps**

Keep the valve caps screwed down firmly. They prevent dirt from entering the valve.

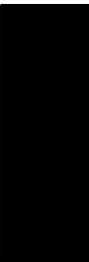

# *Tyres*

---

## **Punctured Tyres**

Your car is fitted with tubeless tyres. These will not normally leak when penetrated by a sharp object, provided it remains in the tyre. If you are aware of this occurring, reduce speed immediately and then drive with caution until the spare wheel can be fitted. Remember, punctured or damaged tyres **MUST** be permanently repaired or replaced **AS SOON AS POSSIBLE**.

## **Replacement Tyres**

Wheel rims and tyres are matched to suit the handling characteristics of the car. Changing the specification of a wheel or tyre can adversely affect the car's handling and, ultimately, your own safety in emergency road situations.

To be safe, **ONLY** fit replacement tyres identical to the original specification shown in '**Technical Data**' at the back of this book.

# Wipers & Washers

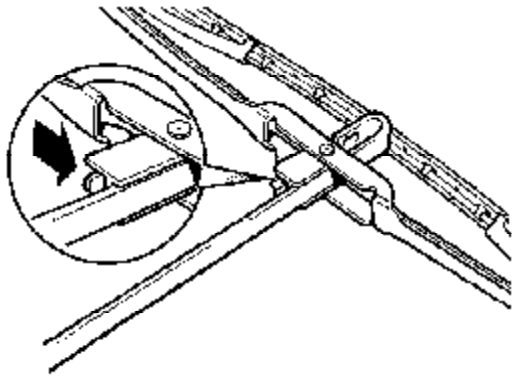

811 0160

## WIPER BLADE RENEWAL

Lift the wiper arm away from the screen, press the retaining clip (arrowed) to release the wiper blade and slide the blade down the arm to withdraw.

To replace, position the new blade assembly on the wiper arm and push into engagement with the crooked end of the wiper arm. Check that it is secure. Always fit replacement wiper blades that are identical to the original specification.

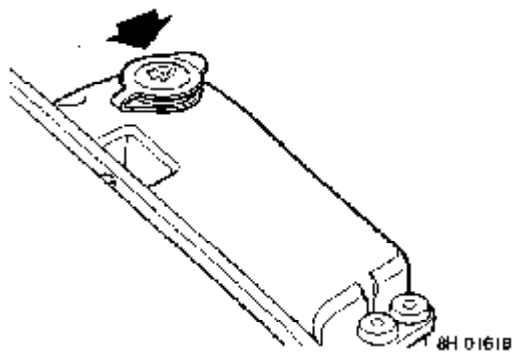

811 0161B

## WINDSCREEN WASHERS

Check the reservoir every week and top-up with a mixture of water and an approved screenwash.

### WARNING!

Do not use an anti-freeze or vinegar/water solution in the screen washer reservoir - anti-freeze will damage painted surfaces, while vinegar can damage the windshield washer pump.

## WASHER JET ADJUSTMENT

Insert a needle into the hole in the jet and lever gently to reposition. Ensure the jets are directed between the midpoint and top of the windscreen.

Use a thin piece of wire as a probe to clean a blocked jet.

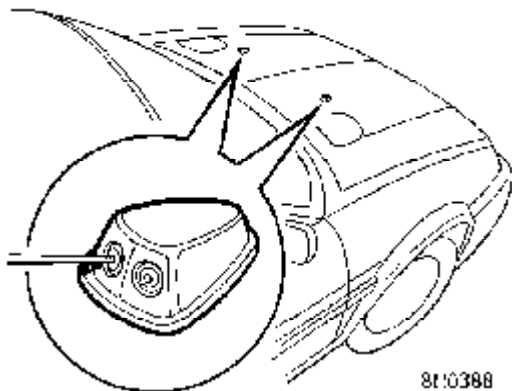

811 0388

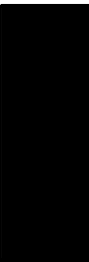

# Battery

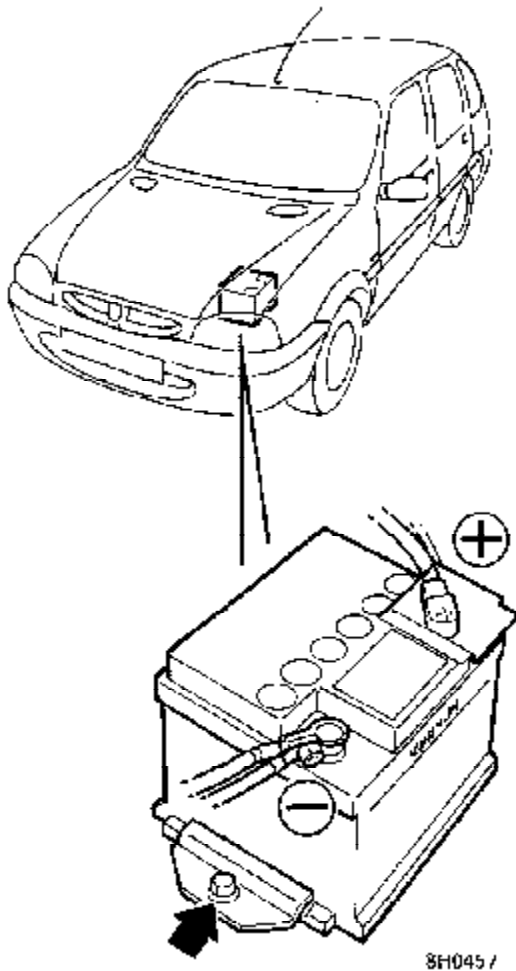

## WARNING!

- Batteries contain sulphuric acid. If the acid comes into contact with the eyes or skin, wash immediately with cold water and seek medical advice.
- During normal operation batteries emit explosive hydrogen gas; ensure sparks and naked flames are kept away from the engine compartment.
- To reduce the risk of a short circuit, remove all metal wrist bands and jewellery before working in the engine compartment and NEVER allow the battery terminals or vehicle leads to make contact with tools or metal parts of the car.
- DO NOT disconnect the battery when the security system is armed.
- To avoid damaging the vehicle's electrical system, ensure correct polarity when refitting the battery.
- ONLY fit a replacement battery of the same type and specification as the original. Other batteries may vary in size and have different terminal positions, capable of creating a potential fire hazard when connected to the car's electrical system.

## BATTERY MAINTENANCE

The battery is designed to be maintenance free, so no topping-up is required.

### Battery Removal & Replacement

ALWAYS turn the starter switch to position '0', switch off all electrical equipment and remove the key before disconnecting the battery.

ALWAYS disconnect the negative (-) terminal first (when replacing, connect the positive (+) first).

To release the battery from the car, undo the battery clamping plate (arrowed in illustration). DO NOT allow the battery terminals to make contact with tools or metal parts of the car.

**Note:** Used batteries are potentially hazardous - dispose ONLY at an authorised disposal site.

## IMPORTANT INFORMATION

If the battery has become discharged while the alarm system is armed, you should be aware that the alarm may start sounding as soon as battery power is restored (when a replacement battery is installed or booster cables are connected). If the alarm starts sounding, disarm the alarm by pressing the handset 'LOCK' button four times in quick succession.

# Battery

---

## **BATTERY CHARGING**

Before charging, ensure the battery is REMOVED FROM THE CAR - charging the battery with the cables connected, can cause serious damage to the car's electrical system.

If your battery has an electrolyte level marked on the casing, ensure the electrolyte is at or above this level before charging. If the electrolyte is below this level, refer to your dealer.

Batteries generate explosive gases, contain corrosive acid and supply levels of electric current high enough to cause serious burns. While charging, always heed the following precautions:

- Make sure the battery charger is disconnected from its power supply before connecting the leads to the battery terminals.
- Make sure the charging leads are securely clamped before switching on the charger, and DO NOT move the clamps while the charger is switched on.
- Shield your eyes or avoid leaning over the battery.
- Keep the area around the top of the battery well ventilated.
- Keep naked flames clear of the battery (batteries emit inflammable hydrogen during and after charging).
- When charging is complete, switch off the charger BEFORE disconnecting the charging leads, and then leave the battery for an hour before reconnection to the vehicle.



# Cleaning & Car Care

---

## WASHING YOUR CAR

Wash your car frequently using a clean, grit-free sponge and generous quantities of cold or warm water containing a car shampoo. Rinse and then dry with a chamois leather.

- In hot weather, DO NOT wash the car in direct sunlight - move the car into the shade!
- DO NOT use hot water!
- DO NOT use detergent soap products or washing-up liquid!

During winter months when salt has been used on the roads, use a hose to wash the underside. Pay particular attention to wheelarches and panel seams, and to removing accumulations of mud.

When using a hose, do not direct the jet into the heater air intake ducts, or through the wheel trim apertures onto the brakes, or at the door seals, where water pressure could unseat the seals.

### WARNING!

Some high pressure cleaning systems are sufficiently powerful to penetrate door and window seals and can also cause damage to rubbing strips and lock mechanisms. Never aim the water directly at door or window apertures, or at components that might easily be damaged.

## Radio Aerial

To prevent damage, unscrew and remove the roof mounted aerial before entering an automatic car wash.

## Getting Rid of Tar Spots

Use white spirit to remove tar spots and stubborn grease stains from paintwork. Then wash with soapy water to remove all traces of the spirit.

## Body Protection

After washing, inspect the paintwork for damage. Treat paint chips and scratches with a Rover touch-up pencil. If the damage has revealed bare metal, use a coloured primer first, then apply the base coat and finish off with a lacquer pencil, if appropriate. Carry out this treatment after washing but before polishing or waxing.

Damaged panels and paintwork must be rectified in accordance with the manufacturer's recommendations. Failure to do this will invalidate the Anti-Corrosion Warranty!

## Glass and Mirrors

*Windscreen:* Always clean the windscreen with glass cleaner after using 'wash and wax' types of car care products, and before fitting replacement wiper blades.

*Rear window:* Clean the inside with a soft cloth using a side to side motion to avoid damaging the heating elements. DO NOT scrape the glass or use an abrasive cleaning fluid.

*Mirrors:* Mirror surfaces are particularly susceptible to damage. DO NOT use abrasive cleaning compounds or metal scrapers when removing snow and ice.

## Wiper Blades

Lift the wiper blades from the screen and wash in warm soapy water, paying particular attention to the wiping edges (NEVER use a spirit or petrol based solvent). Dry with a soft lint free cloth.

# *Cleaning & Car Care*

---

## **LOOKING AFTER THE INTERIOR**

- Clean plastic-faced or cloth upholstery with diluted upholstery cleaner.
- Leather seats and steering wheels should be cleaned with warm water and a non-detergent soap. Dry and polish the leather with a dry, clean, lint-free cloth.
- DO NOT use petrol, detergents, furniture creams or polishes!
- Clean carpets with a brush or vacuum cleaner and occasionally clean with diluted nylon upholstery cleaner.

### **Seat Belts**

Extend the belts, then use warm water and a non-detergent soap to clean. On no account use bleaches, dyes or cleaning solvents - these could weaken the belt webbing. Finally, allow the belts to air-dry naturally, and do not retract them, or use the car, until they are completely dry.

### **Airbag SRS Module Cover**

To protect the airbag module from damage, the steering wheel centre pad should ONLY be cleaned sparingly with a damp cloth and upholstery cleaner.

DO NOT allow the airbag SRS module cover to be flooded with liquid, and DO NOT use petrol, detergents, furniture cream or polishes.

### **Clock, Instruments & Radio**

Clean with a dry cloth only. DO NOT use cleaning fluids or sprays.



# *Emergency Starting*

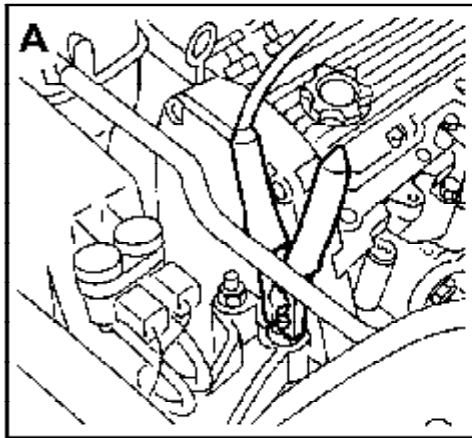
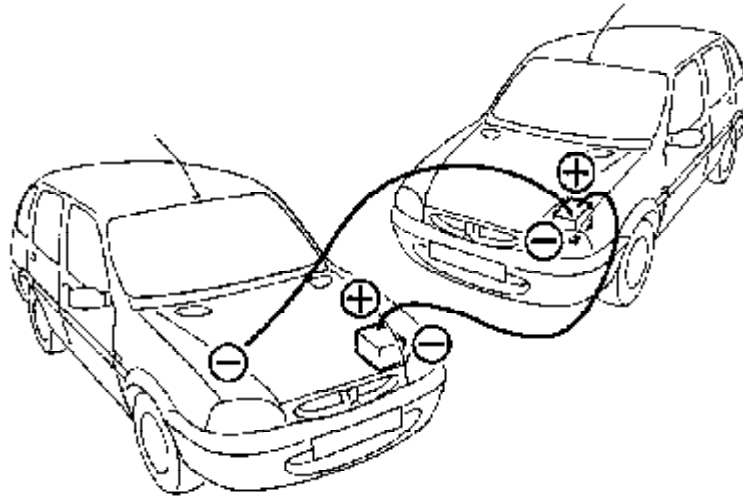

*Earthing point for petrol engine cars.*

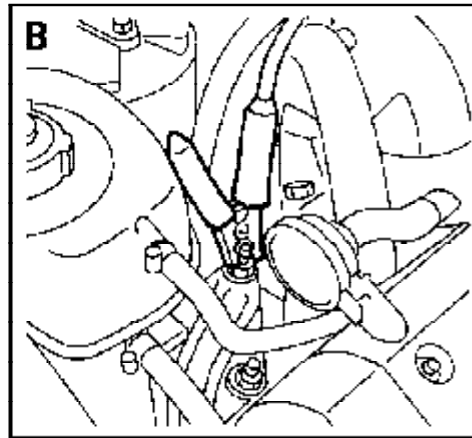

8110456

*Earthing point for diesel engine cars.*

## **WARNING!**

- During normal use, batteries emit explosive hydrogen gas, sufficient to cause severe explosions capable of causing serious personal injury - ensure sparks and naked lights are kept well away from the engine compartment.
- DO NOT disconnect the discharged battery.
- Make sure BOTH batteries are of the same voltage (12 volts), and that the booster cables have insulated clamps and are approved for use with 12 volt batteries.
- DO NOT connect positive (+) terminals to negative (-) terminals, and ensure booster cables are kept away from any moving parts in the engine compartment.

# *Emergency Starting*

---

## **USING BOOSTER CABLES**

Using booster cables (jump leads) from a donor battery, or a battery fitted to a donor vehicle, is the only approved method of starting a car with a flat battery. Push or tow starting is NOT recommended!

1. If a donor vehicle is to be used, both vehicles should be parked with their battery locations adjacent to each other. Ensure that the two vehicles do not touch.
2. Apply the handbrakes and ensure that the transmission of both vehicles is set in neutral ('P' or Park for vehicles with automatic transmission).
3. Turn off the starter switch and ALL electrical equipment of BOTH vehicles.
4. Connect the RED booster cable between the positive (+) terminal of the donor battery and the positive (+) terminal of the discharged battery.
5. Connect the BLACK booster cable from the negative (-) terminal of the donor battery to a good earth point (eg. an engine mounting, chassis member or other unpainted surface). On petrol engine cars the engine mounting bolt identified in illustration 'A' should be used, while for diesel engine cars, a similar bolt shown in illustration 'B' is recommended. **For safety reasons DO NOT connect a booster cable to the negative (-) terminal of the discharged battery!**
6. Check that the booster cables are clear of any moving parts in either engine, then start the engine of the donor vehicle and allow it to idle for a few minutes.
7. Now start the engine of the disabled vehicle (DO NOT crank the engine for longer than 10 seconds at a time).
8. Once both engines are running normally, allow them to idle for two minutes before switching off the engine of the donor vehicle and disconnecting the booster cables. DO NOT switch on any electrical circuits on the previously disabled vehicle until AFTER the booster cables have been removed.
9. Disconnecting the booster cables must be an EXACT reversal of the procedure used to connect them, ie; disconnect the BLACK cable clip from the earth point on the disabled vehicle FIRST!



# Emergency Towing

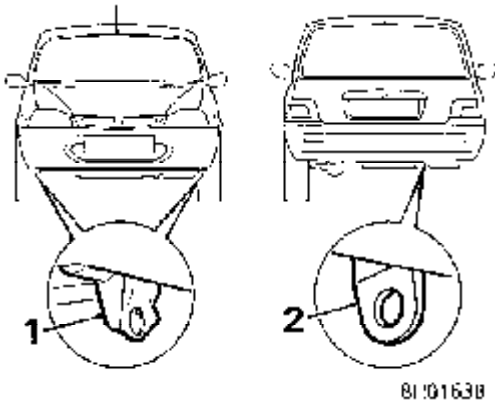

1. Front Towing Eyes
2. Rear Towing Eye

The towing eyes are intended for use by the emergency services, or qualified recovery specialists, to assist in the recovery of your car should a breakdown or accident occur.

### Transporter Lashing

If your car should require securing on the back of a trailer or transporter, use the front and rear towing eyes as lashing points. **DO NOT** attach lashing hooks or trailer fixings to any other parts of the car.

### Towing for Recovery

If your car is to be towed, most qualified recovery specialists will use wheel-free equipment to suspend the front wheels, while the rear wheels remain on the road. However, if it is necessary for the car to be towed with all four wheels on the ground, use the following procedure.

Before being towed:

- Turn the starter key to position 'I' to unlock the steering, and then to position 'II' to enable the brake lights, wipers and direction indicators to be operated if necessary.
- Place the gear lever in neutral.
- Release the handbrake.

**Note:** If the transmission is faulty, the car should be moved on suspended tow to prevent more serious damage occurring.

### Automatic Transmission

In addition to the above, the following precautions must also be observed:

1. The selector lever **MUST** be at 'N'.
2. The car should only be moved on suspended tow (towed with the front wheels raised), or loaded onto a trailer, because the gearbox is not adequately lubricated without the engine running.

### WARNING!

**DO NOT** attempt to tow the car unless the starter switch is turned to position 'I', in order to unlock the steering (if, due to an accident or electrical fault, this is considered unsafe, disconnect the battery before turning the switch).

**DO NOT** remove the key, or turn the starter switch to position '0', while the car is in motion.

Without the engine running, the brake servo cannot provide assistance. Greater effort will therefore be required to operate the brake pedal, and longer stopping distances will also be experienced.

# Wheel Changing

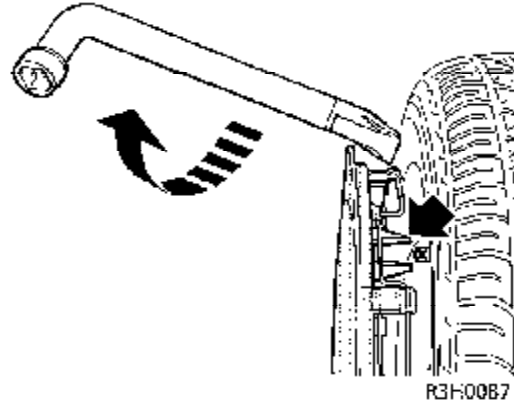
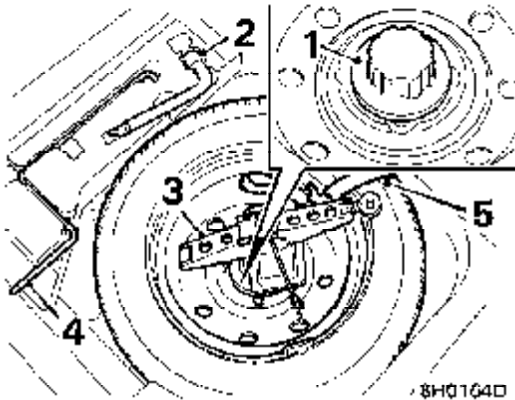

1. Spare Wheel Clamp
2. Wheel Nut Spanner & Trim Remover
3. Jack
4. Jack Handle
5. Lifting strap - Cabriolet model

## Removing the Spare Wheel (not Cabriolet model)

- Lift the luggage compartment floor covering and remove hardboard panel.
- Remove the jack from the centre of the wheel, unscrew the spare wheel clamp to release the spare wheel.

## Removing and Replacing the Wheel Trims

- *Steel Wheels:* Slide the flat end of the wheel nut spanner behind the edge of the wheel trim. Apply a twisting action to the tool, at the same time pulling the trim from the wheel. Work carefully around the wheel trim until it is released.
- When refitting the wheel trim, make sure the valve stem is located between the valve stem guides (arrowed in illustration above), then use firm pressure around the edge to push the trim securely into position.

**WARNING!** To avoid injury from passing vehicles, choose a safe place to stop as far from the thoroughfare as possible. Ensure your passengers get out of the car and wait in a safe area away from passing traffic.

**ALWAYS** switch on the hazard warning lights and use any other available warning devices to alert other road users.

**ALWAYS** ensure the jack is positioned on firm, level ground. Do not position the jack on metal gratings or manhole covers, or use additional material between the base of the jack and the ground.

**ALWAYS** apply the handbrake and engage 1st gear (select 'P' for automatic transmission). If jacking the car on a slope, place chocks at the front and rear of the wheel diagonally opposite the one to be removed.

**NEVER** jack the car with people inside, or with a caravan or trailer connected!

**NEVER** work beneath the car with the jack as the only means of support. The jack is designed for wheel changing only and should not be used for any other purpose!

# Wheel Changing

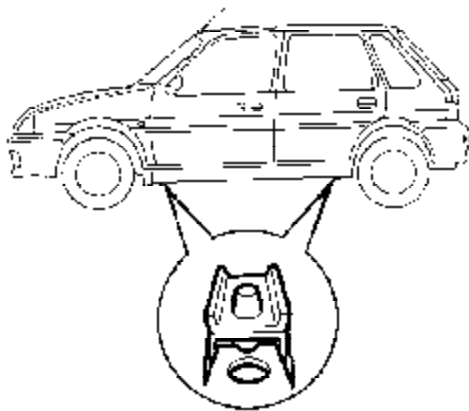

## Positioning the Jack

- Partially extend the jack by turning the jack screw clockwise.
- Position the jack under the jacking point nearest the wheel to be removed.
- Continue turning the jack screw until the head of the jack is in contact with the jacking point. Ensure the peg on the jack head locates securely into the circular hole in the jacking point as shown.

## POSITIONING THE JACK ON CARS FITTED WITH EXTENDED SILL FINISHERS

On some models access to the FRONT jacking points is partly obscured by the extended sill finishers. On these cars it is necessary to locate the peg on the jack head into the larger hole shown in the illustration.

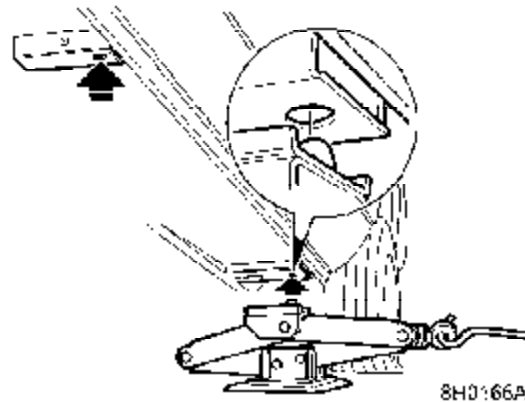
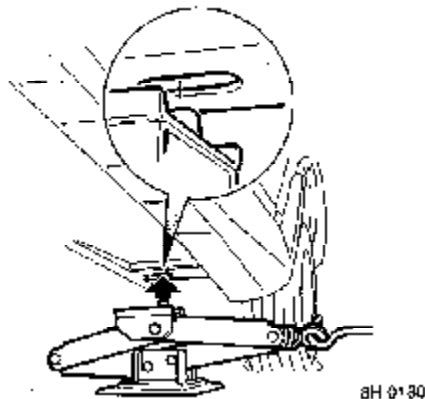

## Changing the Wheel

- Before raising the car, use the wheel nut spanner to slacken the wheel nuts half a turn anti-clockwise.  
**Note:** If locking wheel nuts are fitted, see information on the following page.
- With the jack head securely located on the jacking point, fit the hooked end of the jack handle and raise the car until the tyre is clear of the ground.
- Remove the wheel nuts and the wheel.
- Fit the spare wheel and tighten the wheel nuts (tapered side towards the wheel) until the wheel is firmly seated against the wheel hub. **DO NOT** tighten fully whilst the tyre is clear of the ground.
- Lower the car, then remove the jack and wheel chocks and fully tighten the wheel nuts in diagonal sequence.
- Finally, refit the wheel trim, making sure the valve stem is located between the valve stem guides (these are arrowed in the wheel trim illustration on the previous page). Use firm pressure around the edge to push the trim into position.

## WARNING!

Check the tyre pressures before driving, and have the tightness of the wheel nuts checked by your dealer as soon as possible!

# Wheel Changing

## Removing the spare wheel (Cabriolet model)

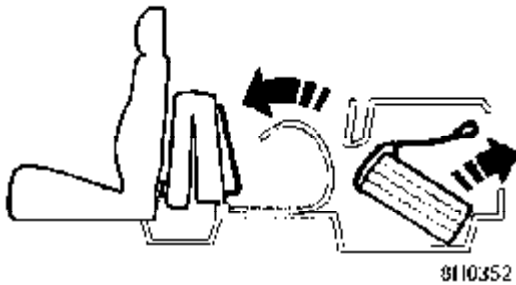

- Fold the rear seat fully forward.
- Lift the luggage compartment floor covering and remove hardboard panel.
- Remove the jack from the wheel centre, and unscrew the clamp to release the spare wheel.
- With the aid of the strap at the front of the wheel, lift the spare wheel into the vertical position.
- Lower the wheel onto the locking sill and lift out spare wheel.
- Transfer the strap onto the wheel to be replaced in the luggage compartment. Reverse removal procedure to place wheel in luggage compartment, ensuring strap is to the front.

### LOCKING WHEEL NUTS

Cars with alloy wheels have one locking wheel nut fitted to each wheel. These are visually very similar to standard wheel nuts but can only be removed using the special tools provided, as follows:

1. Push the extractor tool over the head of the nut and pull to remove the stainless steel nut cover.
2. Fit the key socket over the locking wheel nut, then fit the wheel nut spanner over the key socket and unscrew.
3. Keep a record of the key socket code number in a safe place. You will need to quote this number if a replacement key socket is required.

Keep the key socket and extractor with the tool kit or, for added security, hide the tools in a position away from the spare wheel.

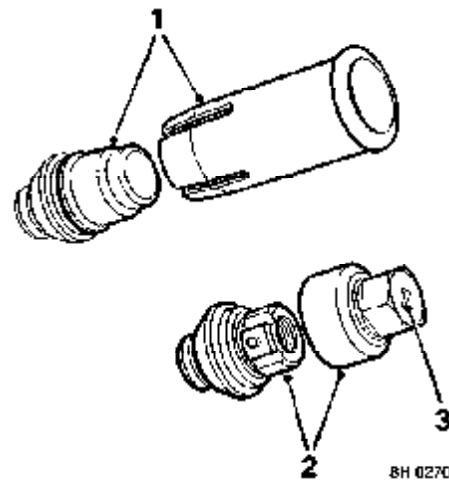

# Fuses

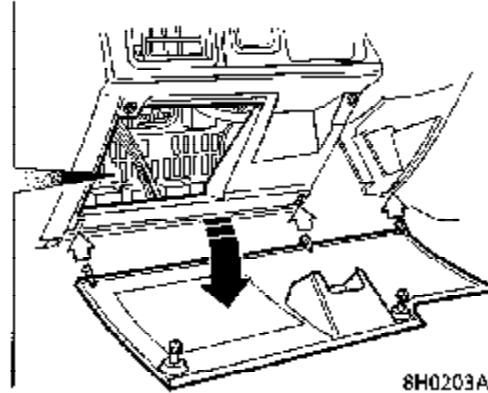
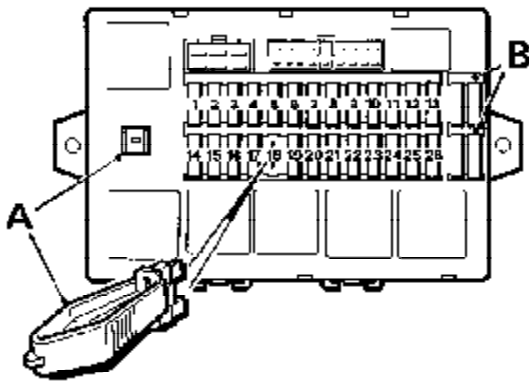

## FASCIA PANEL FUSES

A fuse is a simple circuit breaker, designed to protect electrical equipment by preventing the electrical circuit from being overloaded. A 'blown' fuse is often indicated when the electrical equipment it protects becomes inoperative. This can be checked by examining the fuse and looking for a break in the wire.

It is quite in order to replace a blown fuse, but if the new fuse blows immediately, there is a fault and the circuit must be checked by your Dealer.

### Renewing a Fuse

Always switch off the ignition and the appropriate electrical circuit before removing or replacing a fuse.

Use a coin to turn the two retaining screws a quarter turn anti-clockwise, then disengage the fuse box cover from its pivots. The position and value of each fuse is shown in the illustration above and also on the inside of the fuse box cover.

Press the fuse removal tweezers (located at A in the illustration) onto the head of a fuse and pull to remove. Always replace a fuse with another of the same value.

**Note:** Four spare fuses (located at 'B' in the illustration) are provided inside the fuse box.

Fuse No	Rating (amps)	These units not operating
1	10	Engine (ignition coil) - petrol engines
2	10	Side, tail and number plate lights RH
3	10	Instruments
4	10	Cooling fan - diesel
5	10	Headlight main beam RH
6	10	Alarm immobiliser - diesel
7	30	Cooling fan
8	30	Cooling fan - diesel Cabriolet hood motor
9	10	Direction indicators, reversing lights, stop lights
10	10	Rear fog guard lights
11	20	Rear screen demister
12	15	Radio cassette memory, clock, interior light, lights on warning buzzer
13	30	Windows
14	15	Heater blower motor
15	15	Windscreen wipers and washers
16	15	Taildoor wiper and washer
17	10	Fuel pump
18	10	Headlight main beam LH
19	20	Headlights, side lights
20	15	Headlights dim/dip
21	20	Hazard lights, horn, central door locking
22	15	Radio, cigar lighter
23	-	Spare
24	10	Headlight dip beam RH
25	10	Headlight dip beam LH
26	10	Side & tail lights

# Bulb Replacement

Before replacing a bulb, always switch off the respective lighting switch to prevent any possibility of a short circuit.

Always replace bulbs with the same type and specification. The designation is marked on the base of the bulb.

## Front Light Unit

**Headlight (1):** Remove rubber cover to gain access to bulb. Detach plug from rear of bulb. 'Spring' wire clips apart to release the bulb.

**Sidelight (2):** Pull to remove bulb holder from light unit. Pull bulb to remove from holder

**Direction indicator (3):** Twist anti-clockwise to release bulb holder. Push and twist to remove bulb.

BULB REPLACEMENT	Watts	Part No.
Headlight - dip/main	60/55	GLB 472
Headlight - dip/main (yellow)	60/55	GLB 476
Sidelight	5	GLB 501
Front indicator light (amber)	21	GLB 344
Rear light cluster:		
Indicator (amber)	21	GLB 344
Reversing	21	GLB 382
Stop/tail	21/5	GLB 380
Number plate light	5	GLB 239
Fog guard light	21	GLB 382
Glovebox light	5	GLB 239
Interior light	10	GLB 245
Luggage compartment light	10	GLB 245
Side repeater light	5	GLB 501

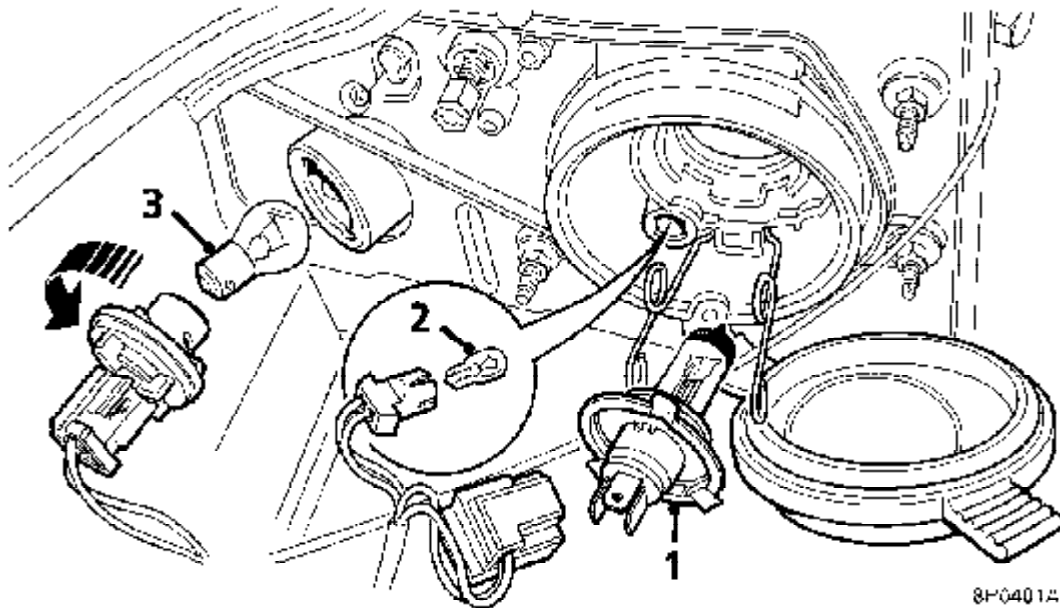

# Bulb Replacement

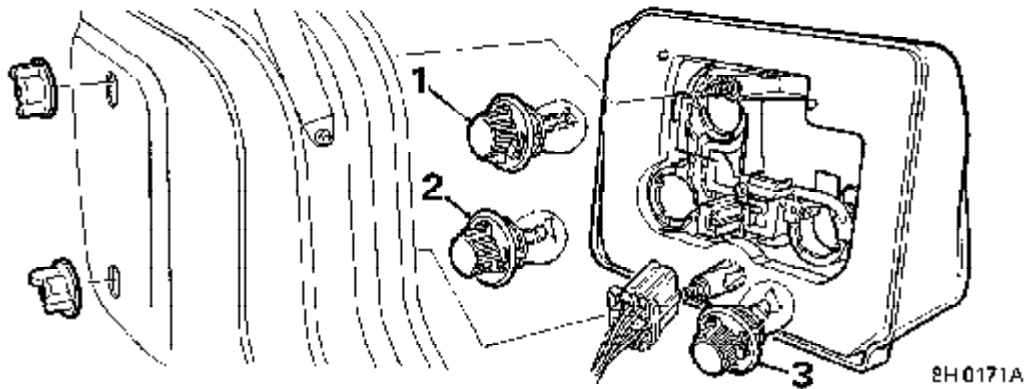

**Rear light cluster - stop/tail(1), direction indicator(2), reversing(3)** Unscrew wing nuts in luggage compartment. Pull light unit from car. Twist bulbs to remove.

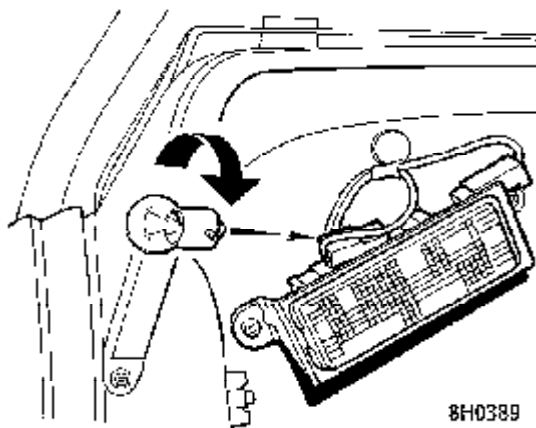

**Luggage compartment light:** Use a small screwdriver to prise the light unit from its mounting bracket. Push and twist the bulb to remove.

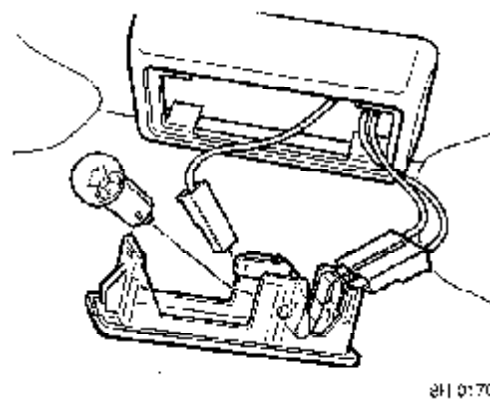

**Interior light:** Use a small screw driver to prise the light unit from its location. Push and twist bulb to remove.

# Bulb Replacement

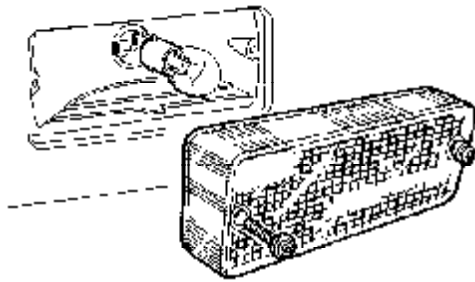

8H0 75A

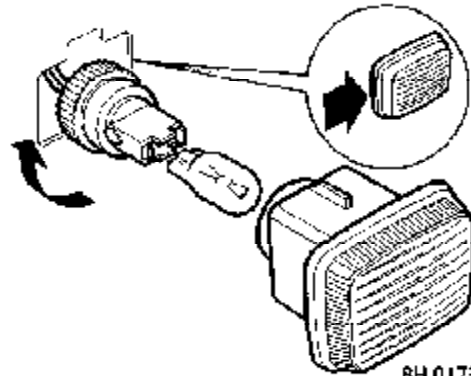

8H 0173A

**Rear fog guard light (driver's side only):** Remove screws and withdraw lens from bumper. Push and turn to remove bulb.

**Side repeater light:** Push light unit to the right to withdraw from wing. Twist bulb holder and pull out bulb.

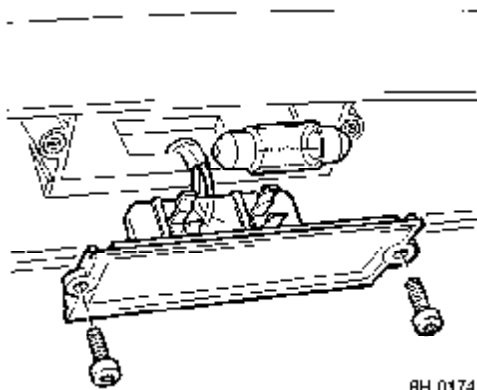

8H 0174

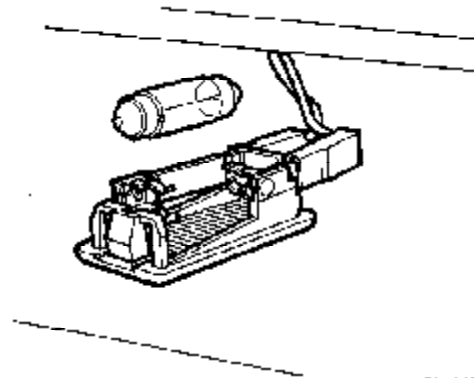

8H 0176

**Number plate lights:** Remove mounting screws and withdraw light unit to gain access to the bulb.

**Glovebox light:** Use small bladed screwdriver to prise lens from roof of glovebox. Spread bulb holders to release bulb.



# Parts & Accessories

---

## SERVICE PARTS & ACCESSORIES

Only Rover dealers are able to provide a full range of recommended parts and accessories that meet our own rigorous standards of safety, durability and performance.

Always consult your dealer for advice regarding the approval, suitability, installation and use of any parts or accessories before fitting.

### WARNING!

The fitting of parts and accessories that have not been approved by Rover may be dangerous and could invalidate the terms and conditions of the vehicle warranty.

If an airbag SRS is fitted, ALWAYS consult a Rover dealer before fitting any accessory.

It is extremely hazardous to fit parts or accessories where installation requires the dismantling of, or addition to, either the electrical or fuel systems.

## Windscreen Replacement

Do not forget to salvage the tax disc and interior mirror from the displaced windscreen. If the Vehicle Identification Number was etched on the displaced windscreen, have the number etched on the new screen.

## Travelling Abroad

In certain countries, legislation prohibits the fitting of parts not to the vehicle manufacturer's specification.

Similarly, owners purchasing accessories while travelling in other countries, should ensure that the accessory and its method of location or fitment to the vehicle will conform to the legal requirements of their own country when they return home.

## IDENTIFICATION NUMBERS

When you communicate with your Dealer you may be required to quote the Vehicle Identification Number (VIN). If your communication concerns the engine, gearbox or body, it may be necessary to quote these numbers as well.

### Vehicle Identification Number.

Stamped on a plate attached to the bonnet locking platform.

The body colour and trim codes are also stamped on the Vehicle Identification Plate and should be quoted if paint or trim items are required.

In addition, as a deterrent to car thieves and to help the police, in some territories the VIN is chemically etched into the bottom of the windscreen and on the rear screen.

### Engine Number

Stamped on the front face of the cylinder block adjacent to the gearbox.

### Gearbox Number

Stamped on a label attached to the front face of the clutch housing.

### Body Number

Stamped on a plate on the R.H. side of the spare wheel compartment.

# Technical Data

---

## Engine - Petrol

Type .....	K Series, 8 valve
Capacity:	
111 models .....	1119 cm <sup>3</sup>
114 models .....	1397 cm <sup>3</sup>
Firing order .....	1 - 3 - 4 - 2
Idle speed .....	850 ± 50 rev/min

## Engine - Diesel

Type .....	TUD 5, 8 valve Diesel
Capacity .....	1527 cm <sup>3</sup>
Firing order .....	1 - 3 - 4 - 2
Idle speed .....	800 ± 100 rev/min
Max. governed speed .....	5000 ± 160 rev/min

## Ignition - Petrol

Type .....	Programmed ignition system
Spark plugs .....	GSP 6662
Gap .....	0.85 mm

## Fuel system - Petrol

Type .....	Electronic single point injection with catalytic converter and feed back control
------------	--

## Electrical

Circuit polarity and voltage .....	Negative (-) earth, 12 V
Battery type .....	Sealed for life

## Dimensions

Overall length .....	3.570 m
Overall height (excluding aerial):	
Cabriolet .....	1.380 m
All other models .....	1.377 m
Overall width (including mirrors) .....	1.775 m
Ground clearance * .....	150 mm
Wheelbase .....	2.269 m
Turning circle (kerb to kerb) .....	9.87 m
Wheel alignment *:	
Front toe-out (inclusive) .....	0° -0° 50'

\* At unladen weight



# Technical Data

---

## Capacities

Fuel tank .....	33 litre
Engine oil refill with filter change:	
Petrol models.....	4.5 litre
Diesel models .....	3.5 litre
Manual gearbox refill .....	2.0 litre
Automatic gearbox refill .....	4.5 litre
Cooling system refill:	
Petrol models.....	4.5 litre
Diesel models .....	5.5 litre
Washer bottle .....	2.6 litre

## Weights

Three door models:	
Chelsea (petrol) .....	840 kg
Chelsea (diesel) .....	890 kg
111 SLi .....	845 kg
115 SLD.....	895 kg
Five door models:	
Chelsea (petrol) .....	855 kg
Chelsea (diesel) .....	905 kg
111 SLi .....	860 kg
114 GSi .....	865 kg
115 SLD.....	910 kg
Max gross vehicle weight .....	1320 kg
Max roof rack weight .....	50 kg
Max towing weight (restart) on a 12%, 1 in 8 gradient with one passenger *	
111 & Chelsea petrol models .....	700 kg
115 & Chelsea diesel models .....	460 kg
114 models .....	800 kg
Towing hitch downward load maximum .....	50 kg

\* Note: Any additional weight, such as luggage or extra passengers, should be deducted from the maximum towing weight quoted above.

# Technical Data

---

## Wheels and tyres:

### Wheel size:

Steel wheel.....	4.5J x 13
Alloy wheel.....	5.5J x 13
Road wheel nut torque .....	70 Nm
Tyre size .....	155/65 R13

## Tyre Pressures (cold)

bar

Petrol cars (manual gearbox) .....	2.1
Petrol cars (auto gearbox) .....	2.3
Diesel cars .....	2.3

